

NORCOLD[®]



Service Manual

Dual Electric Refrigerator

A large, stylized letter 'P' graphic that serves as a background for the model list. It consists of a vertical line on the left and a large curved shape on the right.

MODELS

DE / EV0041

DE / EV0061

INTRODUCTION

About this Manual

This service manual provides diagnostic and repair information for **NORCOLD**® DE0041, EV0041, DE0061, and EV0061 refrigerators. It is a reference tool designed for technicians who are knowledgeable on **NORCOLD**® dual electric refrigerators (AC/DC power) installed in recreational vehicles, commercial over the road vehicles, marine applications, as well as under-the-counter installations.

The information, illustrations, and specifications contained in this publication is based on the latest product information available at the time of publication approval. **NORCOLD**® reserves the right to make changes at any time without prior notification.

Model Description

All DE0041 and DE0061 operate on 120 volt alternating current (Vac) and 12/24 volts direct current (Vdc).

All EV0041 and EV0061 operate on 240 volt alternating current (Vac) and 12/24 volts direct current (Vdc).

Product Information Label

The product information label is affixed to the upper right side of the fresh food compartment. See Figure 1 and Figure 2. The label provides the following information.

- Model Number.
- Serial Number.
- AC voltage and amperage.
- DC voltage and amperage.
- Refrigerant type and capacity.
- UL compliance logo.

Replacement Parts

Use only authorized **NORCOLD**® replacement parts. Generic parts do not meet **NORCOLD**® specifications for safety, reliability, and performance. The use of unauthorized aftermarket, or generic replacement parts voids the refrigerator's limited warranty coverage.

Technical Assistance

If unable to resolve technical issues using the information provided in this manual, technical assistance is available through **NORCOLD**® Customer Service Center.

- ☎ Telephone ----- 1-800-444-7210
- ☎ Fax ----- 1-937-497-3183
- ✉ Email ----- www.norcold.com

The following information is required to process all technical assistance requests.

- Model number.
- Serial number.
- Make, model, and year of vehicle/marine application.

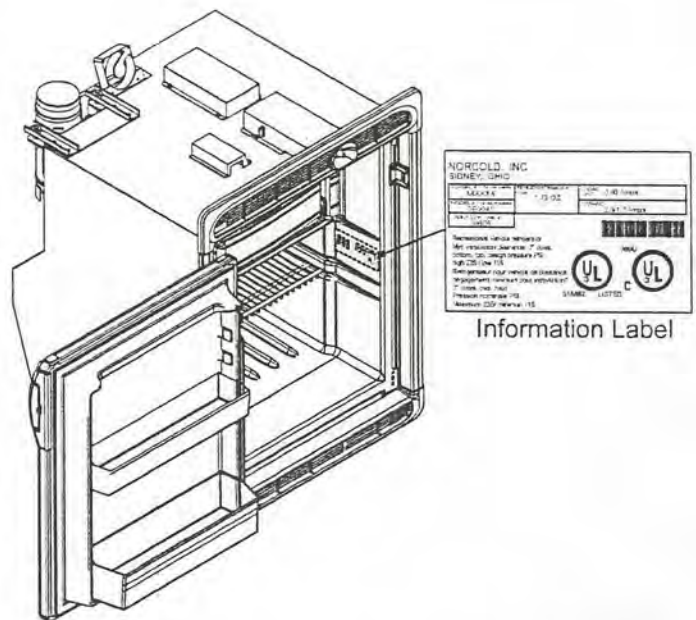

Figure 1. DE0041/EV0041 Information label location.

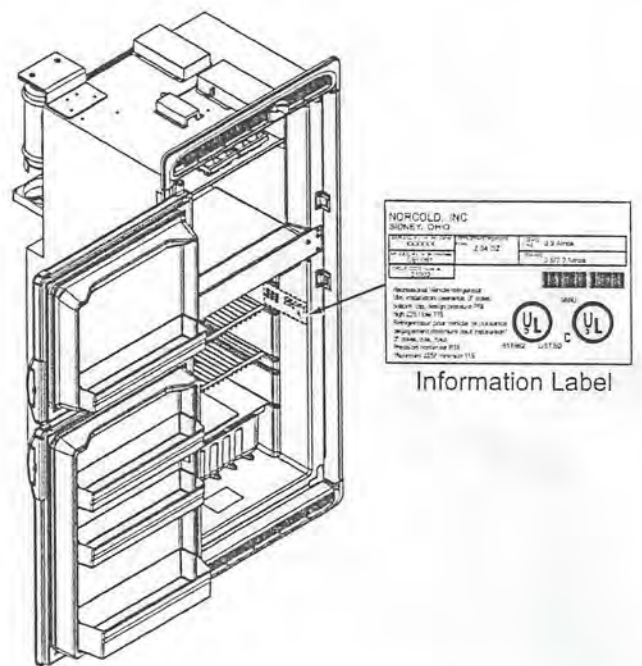

Figure 2. DE0061/EV0061 Information label location.

Safety Notice

It is not possible to anticipate all of the conceivable ways or conditions under which the refrigerator may be serviced or to provide cautions as to all of the possible hazards that may result. Standard and accepted safety precautions and equipment should be used when working on electrical circuits and handling the cooling unit. Safety goggles and other required protection should be used during any process that can cause material removal, such as cleaning components.

Attention Statements

The safety alert symbol  followed by the word **WARNING!** or **CAUTION!** identifies potential safety hazards or conditions.













WARNING!

The above heading identifies hazards or conditions, which if ignored, can cause a serious injury, death, and/or extensive property damage.

CAUTION!

The above heading identifies hazards, which if ignored, can cause injury and/or property damage.

Safety Statements

-  Incorrect installation, adjustment, alteration, or maintenance of this refrigerator can cause personal injury, property damage, or both.
-  Refer to the *DE / EV0041, DE / EV0061 Installation and Owner's Manual (Part No. 623540A)* to remove and reinstall the refrigerator. Comply with all guidelines and installation instructions..
-  Make sure that all electrical installations and repairs comply with all applicable codes and the *DE / EV0041, DE / EV0061 Installation and Owner's Manual (Part No. 623540A)*.
-  **Do not work on live circuits!** De-energize AC power and DC power sources before attempting to remove, service, or replace any of the refrigerators' electrical or electronic components.
-  **Do not** modify, bypass, or eliminate any of the refrigerators' electrical components, electronic circuits, or overheating protection shut off device. Modifying, bypassing, or eliminating any of the refrigerator circuits will void the refrigerator's limited warranty.
-  **Do not** wet or spray liquids on or near electrical connections or electronic components. Many liquids are electrically conductive and can create an electric shock hazard, short electrical components, damage electronic circuits, and/or ignite a fire.
-  The refrigerator cooling system is under pressure. **Do not** attempt to repair or recharge the cooling system. **Do not** bend, drop, weld, drill, puncture, saw, or strike the cooling system. The cooling system contains R134a refrigerant.
-  **Do not** remove the grounding prong from the refrigerator AC power cord plug.
-  **Do not** use a two prong adapter to connect the refrigerator AC power cord to an outlet.
-  **Do not** under or over-fuse electrical circuits. Use the specified fuse and the correct AWG wire size. Refer to the *DE / EV0041, DE / EV0061 Installation and Owner's Manual (Part No. 623540A)* for AWG wire size and fuse specifications.
-  **Prevent child entrapment!** Remove all doors and make sure all shelves are fastened with retainers before disposing of the refrigerator.
-  Certain refrigerator metal components have sharp corners and edges. Wear hand protection, such as cut resistant gloves, and exercise extreme care when handling the refrigerator.
-  Make sure all fasteners and connections are tight.

VENTILATION

Fan

Fan operation is controlled by a temperature sensor in the DC power supply circuitry. The sensor turns on the fan when the temperature reaches 95 °F (35 °C). Fan location for the DE0041/EV0041 is shown in Figure 3. Fan location for the DE0061/EV0061 is shown in Figure 4;

Amp Draw

The DE / EV 0041 fan motor draws 0.15 amps @ 24 volts.
The ED / EV 0061 fan motor draws 0.10 amps @ 24 volts.

Service and Maintenance

Chirping or rattling noise usually indicate worn fan motor bearings and required fan replacement. Fan blades should be cleaned annually. Dust buildup on fan blades can be cleaned using a small brush to dust off the top and underside of each blade.

Overheating Protection

DE0041T and DE0061T are equipped with an overheating protection sensor. The sensor is in the DC power supply circuitry. It shuts off power to the compressor and sounds an intermittent beeping alarm if the temperature in the DC power supply reaches or exceeds 110° F (43° C).

Overheating usually results from operating the refrigerator in high ambient temperatures of 110° F (43° C) or higher, blockage of air intake vent, air outlet vent, or dirty fan blades. To restart the refrigerator after correcting the cause of overheating:

NOTE

Refrigerator operation cannot be restored until the air temperature in the enclosure falls below 110° F (43° C).

1. Turn off the refrigerator.
2. Allow the air temperature in the enclosure to cool below 95° F (35° C).
3. Turn on the refrigerator.

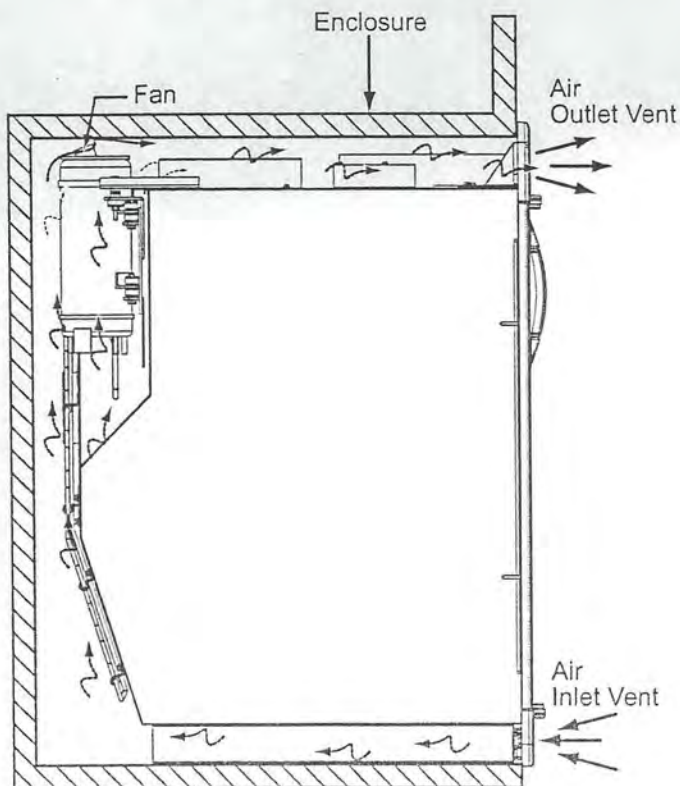

Figure 3. DE0041/EV0041 ventilation airflow.

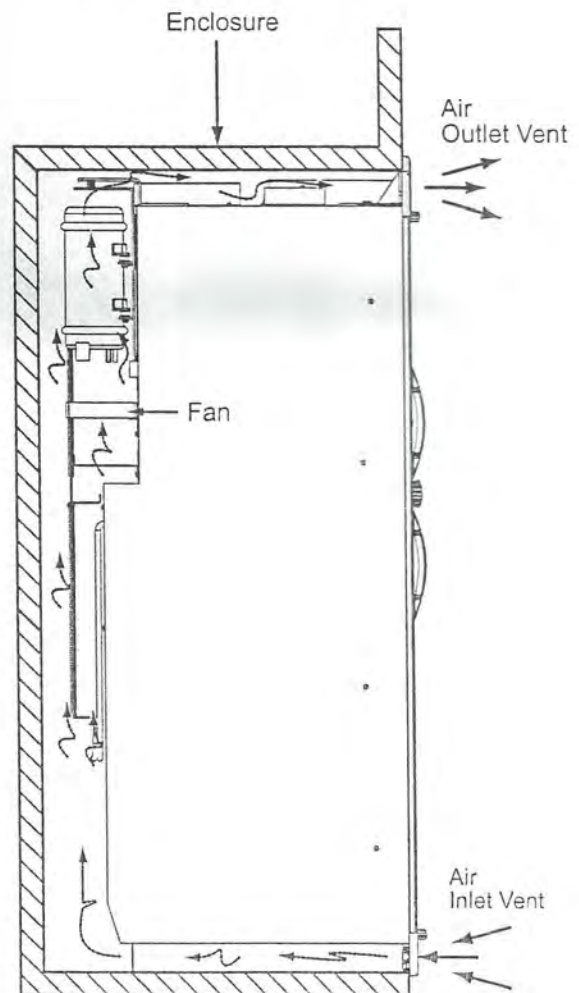

Figure 4. DE0061/EV0061 ventilation airflow.

POWER SUPPLIES

Description

The DC power supply, AC power supply and interior light power board are mounted on top of the refrigerator cabinet. See Figure 5 and Figure 6. The refrigerator must be removed from the enclosure to service, troubleshoot, and replace these components.

DC Power Supply

The DC Power Supply is rated for 12 or 24 Vdc operation. The minimum voltage required for operation is 10.5 Vdc; maximum is 30.5 Vdc. The power switch/thermostat control and power Indicator Light (green LED) are components of the DC Power Supply. See Figure 5 and Figure 6. Figure 7, Page 6 shows the DC Power Board and its connectors.

Fuses DE0041/EV0041

The DE0041/EV0041 DC power supply has a 10 amp fast acting blade-style standard automotive fuse (red) located on the side of the power supply and a 10 amp fast acting AGC style in-line fuse on the negative wire.

Fuses DE0061/EV0061

The DE0061/EV0061 DC power supply has a 15 amp fast acting blade-style standard automotive fuse (blue) located on the side of the power supply and a 15 amp fast acting AGC style in-line fuse on the negative wire.

DE Models AC Power Supply

DE models power supply is rated for 120 Vac. It requires a minimum voltage 108 volts; the maximum is 132 Vac. It supplies 35 to 47 Vdc to the DC power supply and interior light power board. See Figure 5 and Figure 6. Figure 8, page 6 shows the AC Power Supply and connectors.

EV Models AC Power Supply

EV models power supply is rated for 240 Vac. It requires a minimum voltage 205 volts; the maximum is 253 Vac. It supplies 35 to 47 Vdc to the DC power supply and to the interior light power board. See Figure 5 and Figure 6. Figure 8, page 6 shows the AC Power Supply and connectors.

Interior Light Power Board

The interior light power board It supplies 12 Vdc to the food cabinet light and the divider heater (DE0061/EV0061 only). The circuit is protected by a 1-amp AGC fuse. The fuse is on the circuit board. The interior power light board and connectors are shown in Figure 9, page 6.

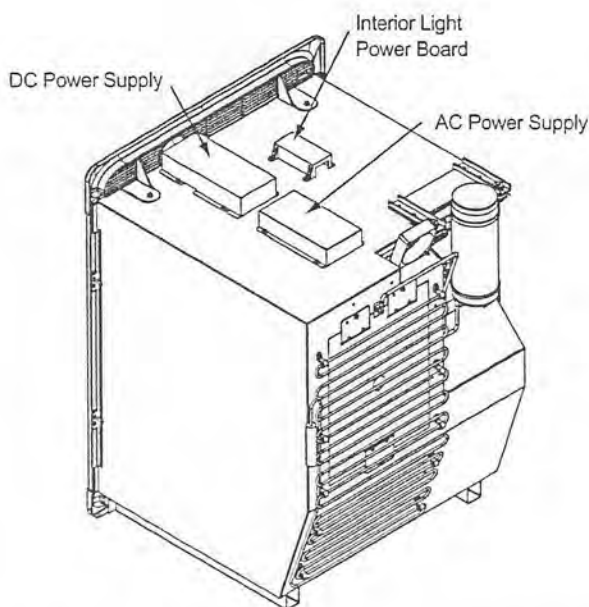

Figure 5. DE0041/EV0041 power supplies arrangement.

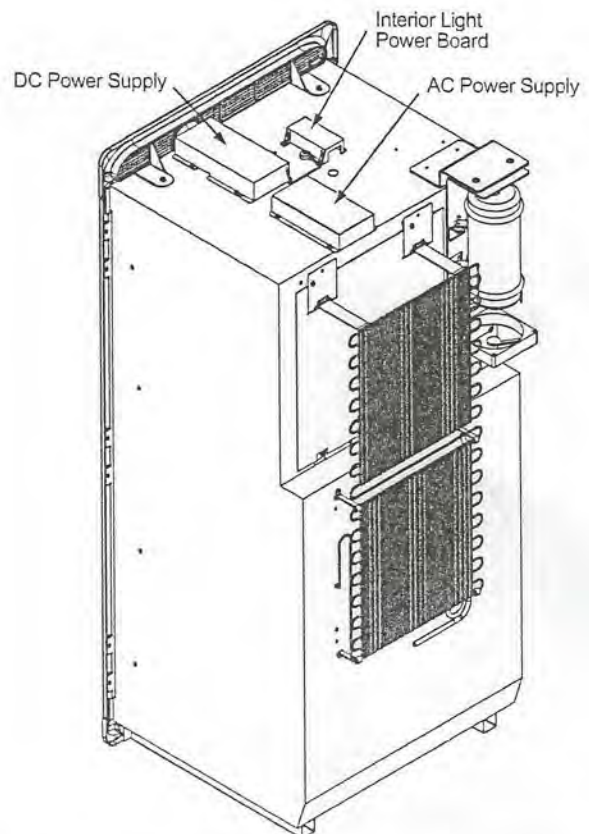

Figure 6. DE0061/EV0061 power supplies arrangement.

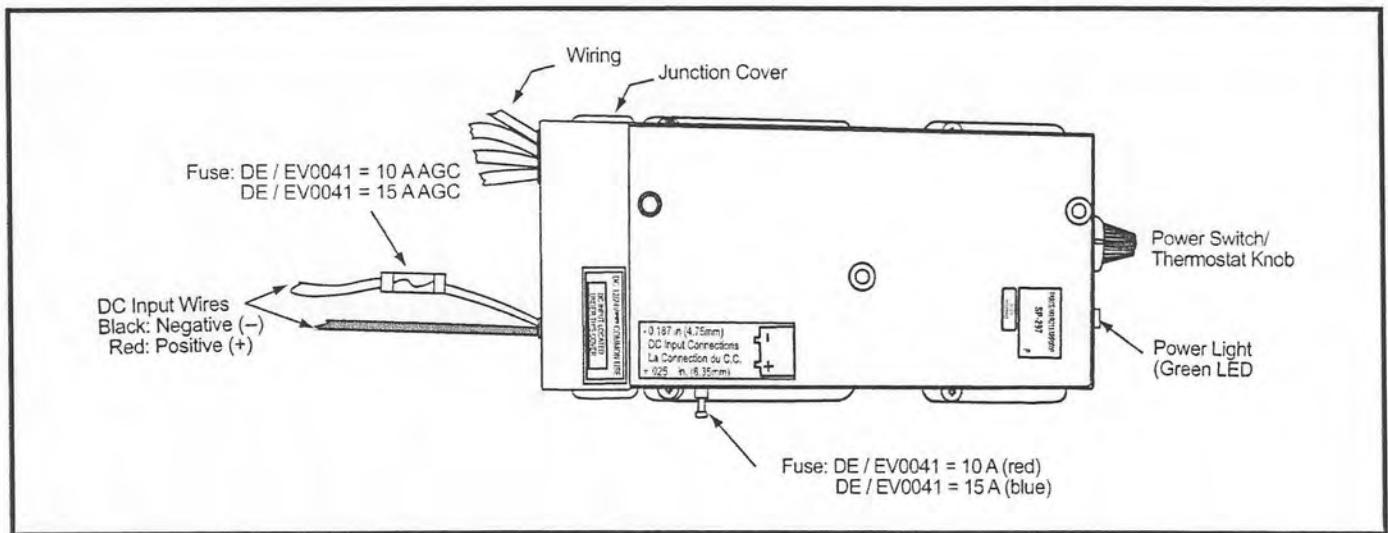

Figure 7. DC Power Supply.

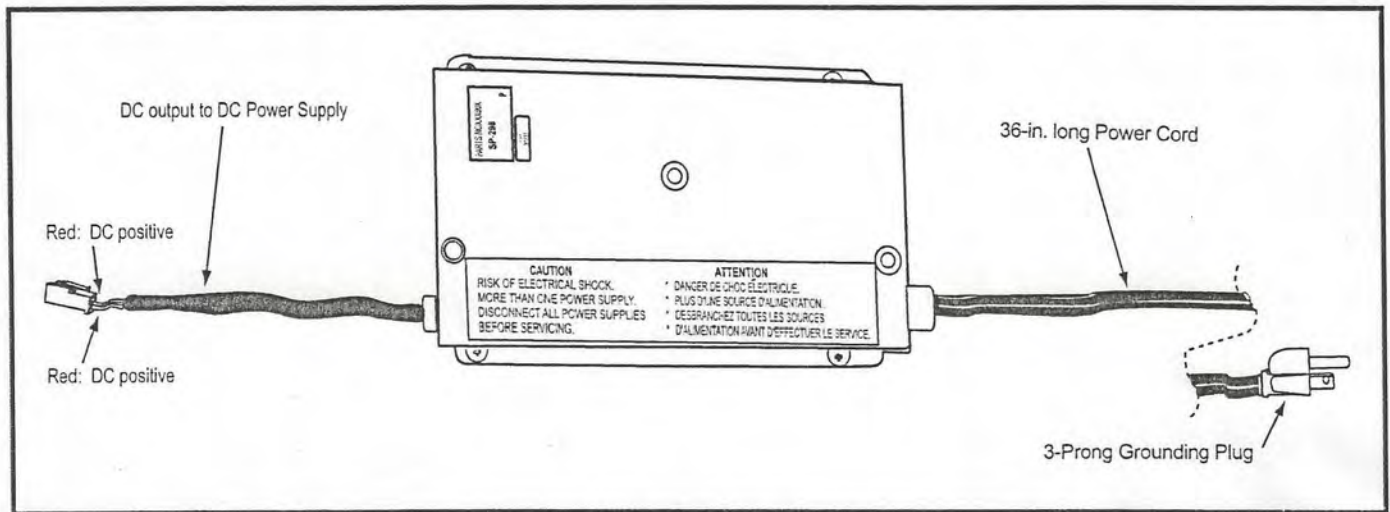

Figure 8. AC Power Supply.

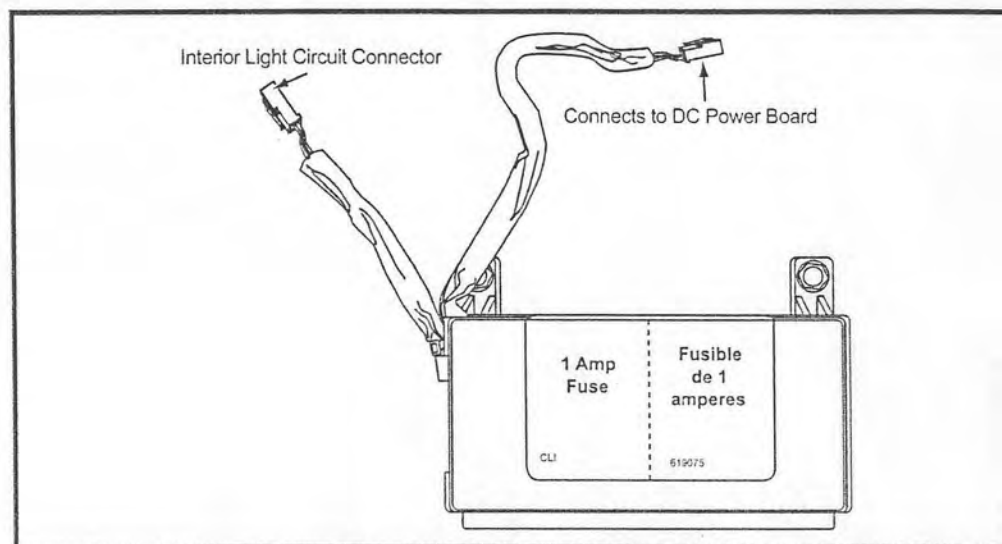
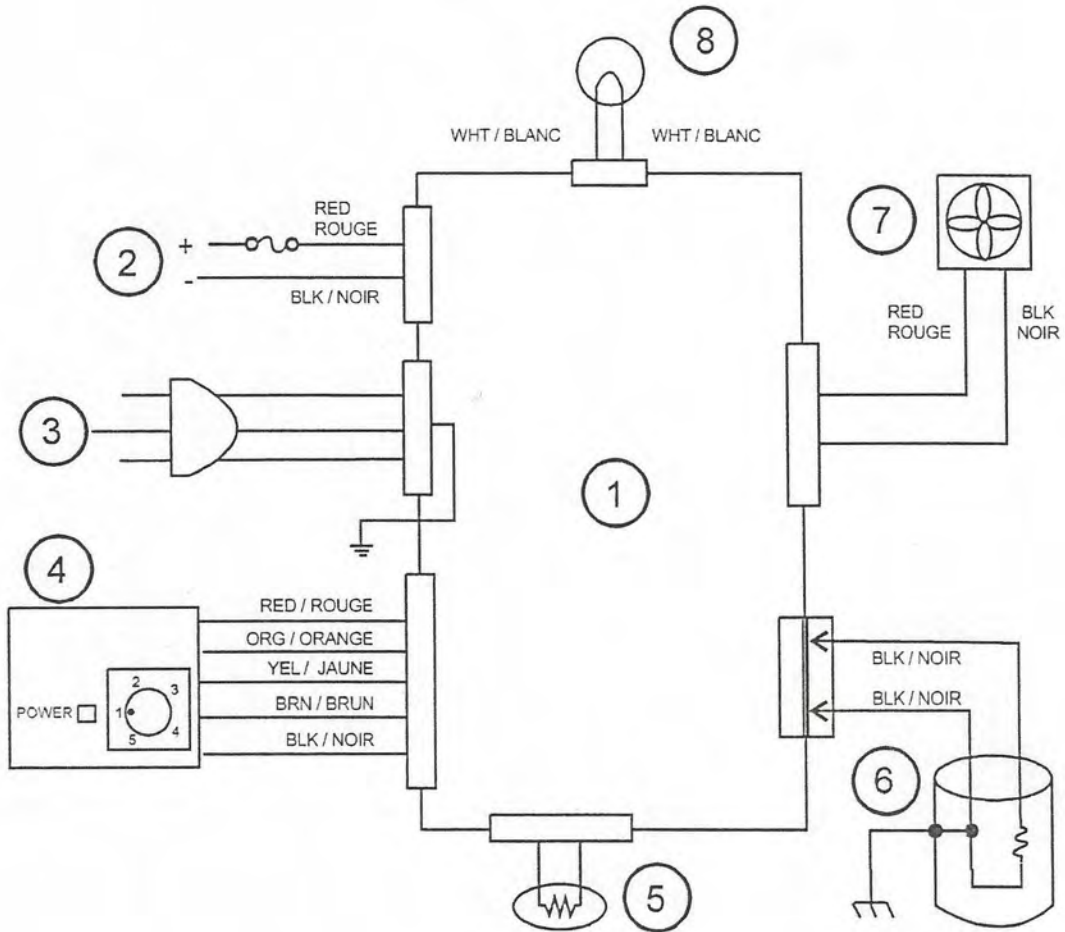

Figure 9. Interior Light Power Board.

Wiring Pictorial



- | | |
|--------------------------------------|----------------------------------|
| ① AC / DC Power supplies | ⑤ Evaporator sensor (thermistor) |
| ② DC voltage input | ⑥ Compressor |
| ③ AC voltage input | ⑦ Fan, 24 Vdc |
| ④ Power switch / Temperature control | ⑧ Fresh food cabinet light |

Procedure-A: Insufficient Cooling, Compressor Runs Continuously

NOTE

Measure input voltage(s) before performing this procedure. Voltage input to power supplies must be between the following range:

VAC	VDC
DE: 85 V min / 132 Vmax	10.5 to 32 Vdc
EV: 205V min / 253 V max.	



CAUTION!

Do not short fan wires. Shorting fan wires will damage the DC Power Supply.

1. Measure voltage across the fan wire harness connector pins.
 - Refrigerator is operating, fan not running —voltage measurement should be negligible.
 - Refrigerator is operating, fan running —voltage measurement should be between 17 to 22 Vdc.

NOTE

The DC Power Supply supplies the fan with 17 to 22 Vdc. For the fan to turn on the compressor must be running and the temperature of the DC Power Supply must be 95° F (35° C) or higher.

2. Test fan operation. To test fan, proceed as follows:
 - a. Turn on refrigerator.



CAUTION!

Do not overheat DC Power Supply! The amount of heat required to energize the fan circuit is minimal. The fan should come on within seconds.

- b. With an air heat gun set to **Low Heat** and its nozzle no closer than 4 inches away from DC Power Supply, apply heat as shown in Figure 12. The fan should come on when the temperature reaches 95° F (35° C). Replace the fan only when all of the following are present:
 - 1) The temperature around the area indicated in Figure 12 is approximately 95° F (35° C).
 - 2) Voltage across the fan wire harness connector pins is 17 to 22 Vdc.
 - 3) The fan does not come on.

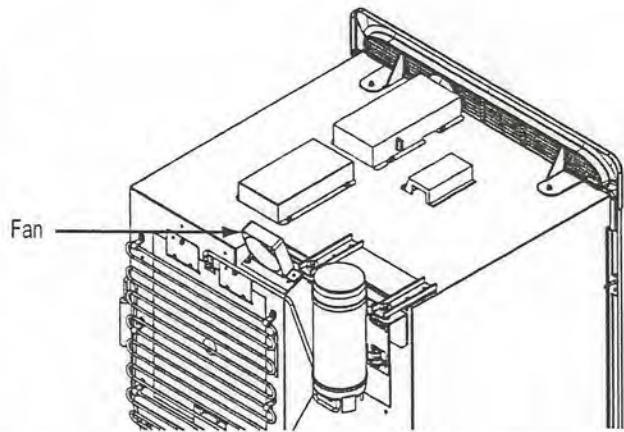

Figure 10. Fan Location-DE / EV0041.

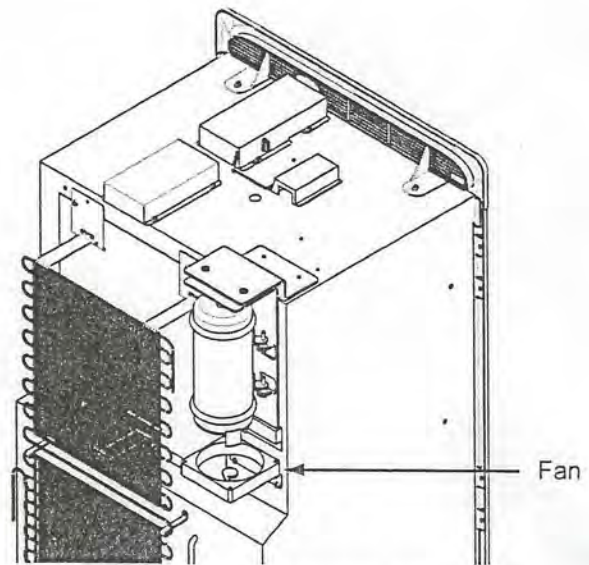

Figure 11. Fan Location-DE / EV0061.

CAUTION!

1. Use low heat setting.
2. Keep heat gun away from plastic components.
3. Keep air heat gun at a distance and moving.

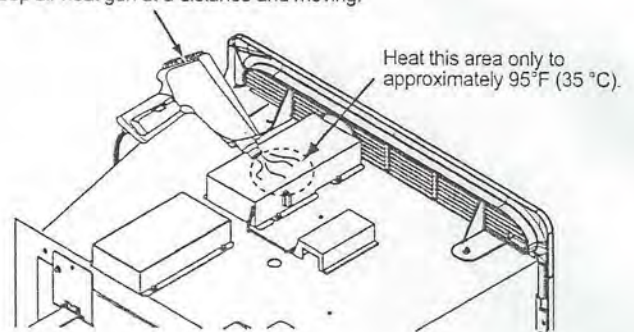

Figure 12. Testing fan operation.

Procedure-B: Temperature Control ON, Compressor Does Not Run

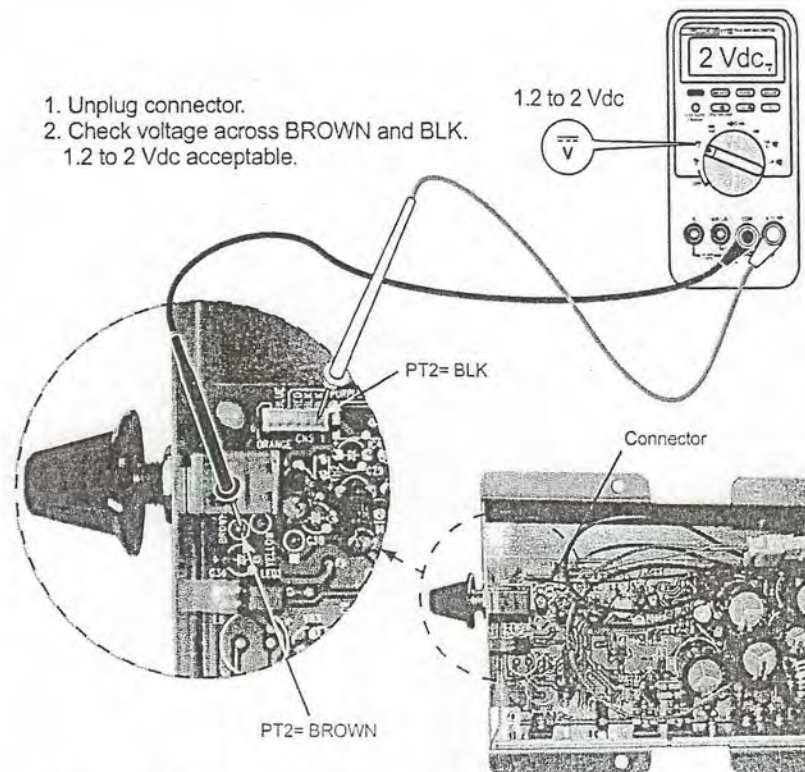
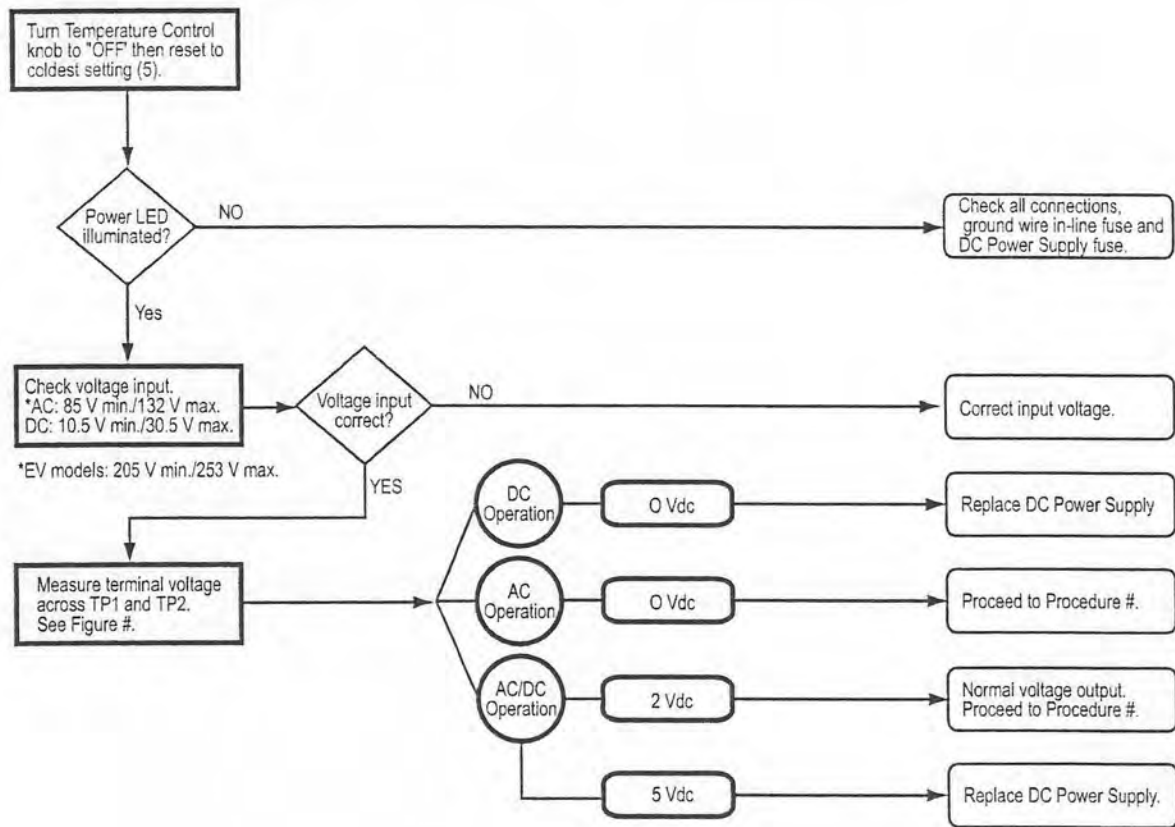
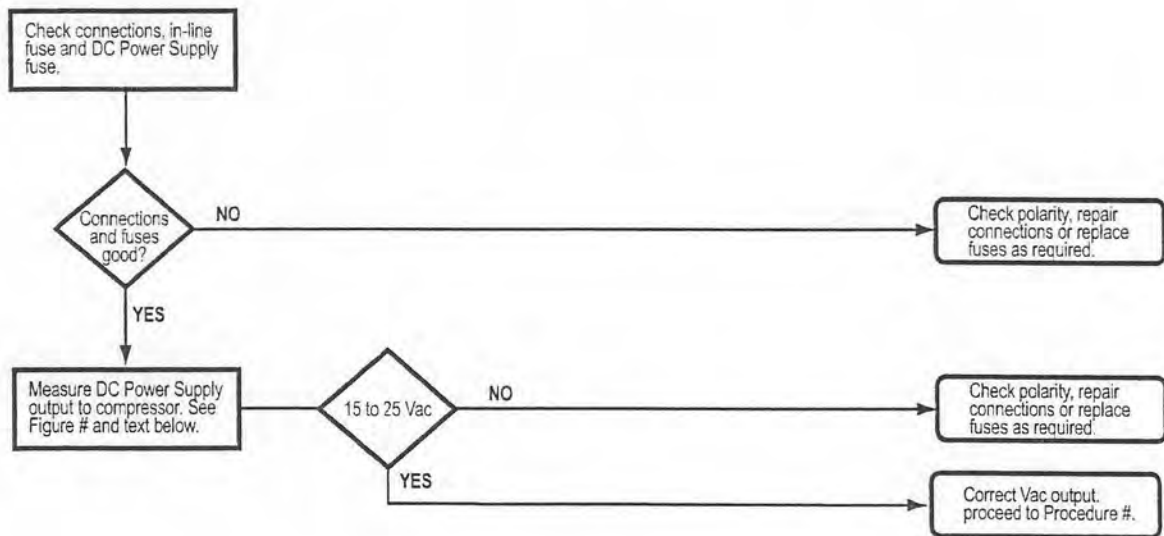
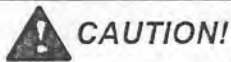

Figure 13. Checking voltage at Temperature Control.

Procedure C: Temperature Control ON, Power Indicator Off, Compressor Does Not Run



Measuring Power Supply Output, Compressor Disconnected



Do not use a converter or battery charger to supply DC power to the refrigerator. These devices do not supply filtered DC power. When Using a converter or battery charger, make sure that a battery is connected in-line between them.

1. Connect the DC power supply to a charged 12 volt automotive battery. Observe the correct polarity (red +/ black -) when connecting the DC Power Supply wires to the battery.
2. Disconnect the line voltage wire from the compressor.
3. Turn on the refrigerator. The power light should illuminate.
4. Measure voltage output at line voltage connector. See Figure 14. Voltage values with the compressor disconnected:

DE/EV0041 17 to 25 Vac.

DE/EV0061 17 to 25 Vac.

The DC power supply must be replaced if the voltage output is not within the specified values.

5. Shift operation to AC power. Plugging the AC cord to a "live" 120 Vac outlet will automatically shift refrigerator to AC operation.
6. Measure voltage at compressor. See Figure 14, See step 4 for voltage output values.

No voltage or voltage is lower or higher than values listed in Step 4, see Procedure D, page 11.

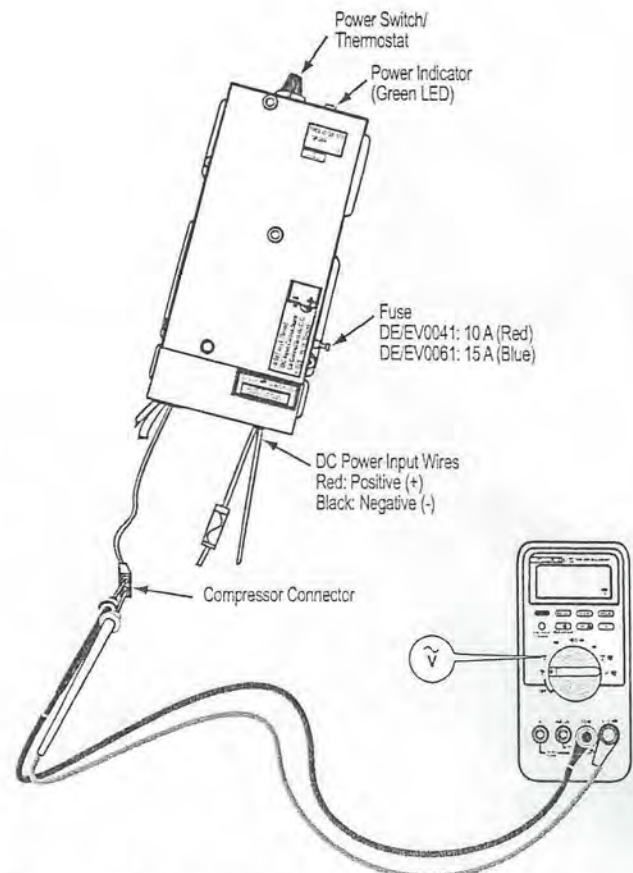
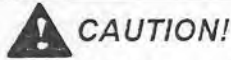

Figure 14. Checking DC Power Supply voltage output.

Procedure D: Measuring Power Supply Output, Compressor Running



Do not use a converter or battery charger to supply DC power to the refrigerator. These devices do not supply filtered DC power. When Using a converter or battery charger, make sure that a battery is connected in-line between them.

1. Make sure power supply wires are connected to the compressor.
2. Connect the DC power supply to a charged 12 volt automotive battery. Observe the correct polarity (red +/ black -) when making connections.
3. Turn on the refrigerator.
4. Measure voltage at the compressor terminal. See Figure 15. Acceptable voltage range with the compressor connected:

DE0041/EV0041	15 to 25 Vac.
DE0061/EV0061	15 to 25 Vac

If no output or voltage output range is outside the values listed above replace DC Power Supply.

NOTE

With the compressor connected, AC voltage across the compressor terminals should measure the same on 12 Vdc 24 Vdc or on AC power operation.

5. Shift operation to AC power. Plugging the AC cord to a "live" 120 Vac outlet will automatically shift refrigerator to AC operation.
6. Measure voltage output across compressor terminals. See Figure 15. See Step 4 for voltage output values.

If no output or voltage output range is outside the values listed above replace AC power supply.

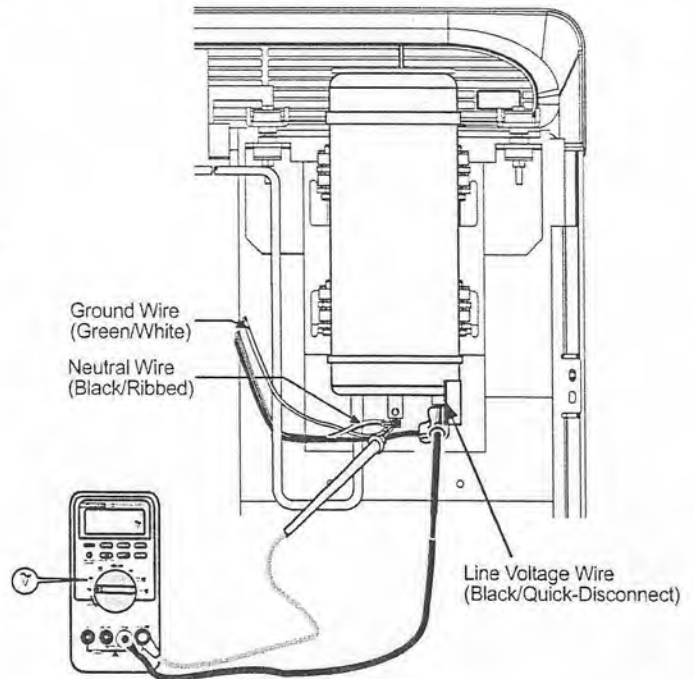
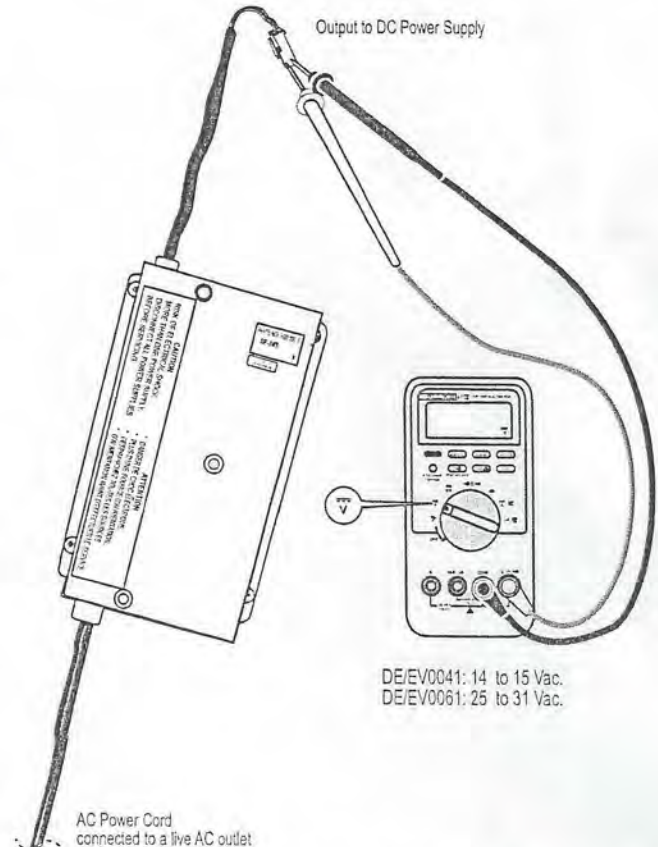

Figure 15. Checking voltage with compressor running.



DE/EV0041: 14 to 15 Vac.
DE/EV0061: 25 to 31 Vac.

Figure 16. Checking AC Power Supply voltage output.

Procedure E: Measuring Compressor Resistance

IMPORTANT!

The specified compressor resistance measurements were established at room temperature. Always make sure that the compressor has cooled down to room temperature before measuring compressor winding resistance.

To measuring compressor resistance:

1. Turn off refrigerator.
2. Allow the compressor to cool down to room temperature.
3. Disconnect the line voltage wire from the compressor. See Figure 17.
4. Measure compressor resistance as shown in Figure 17. Resistance should measure between 1.4 and 3.5 ohms.

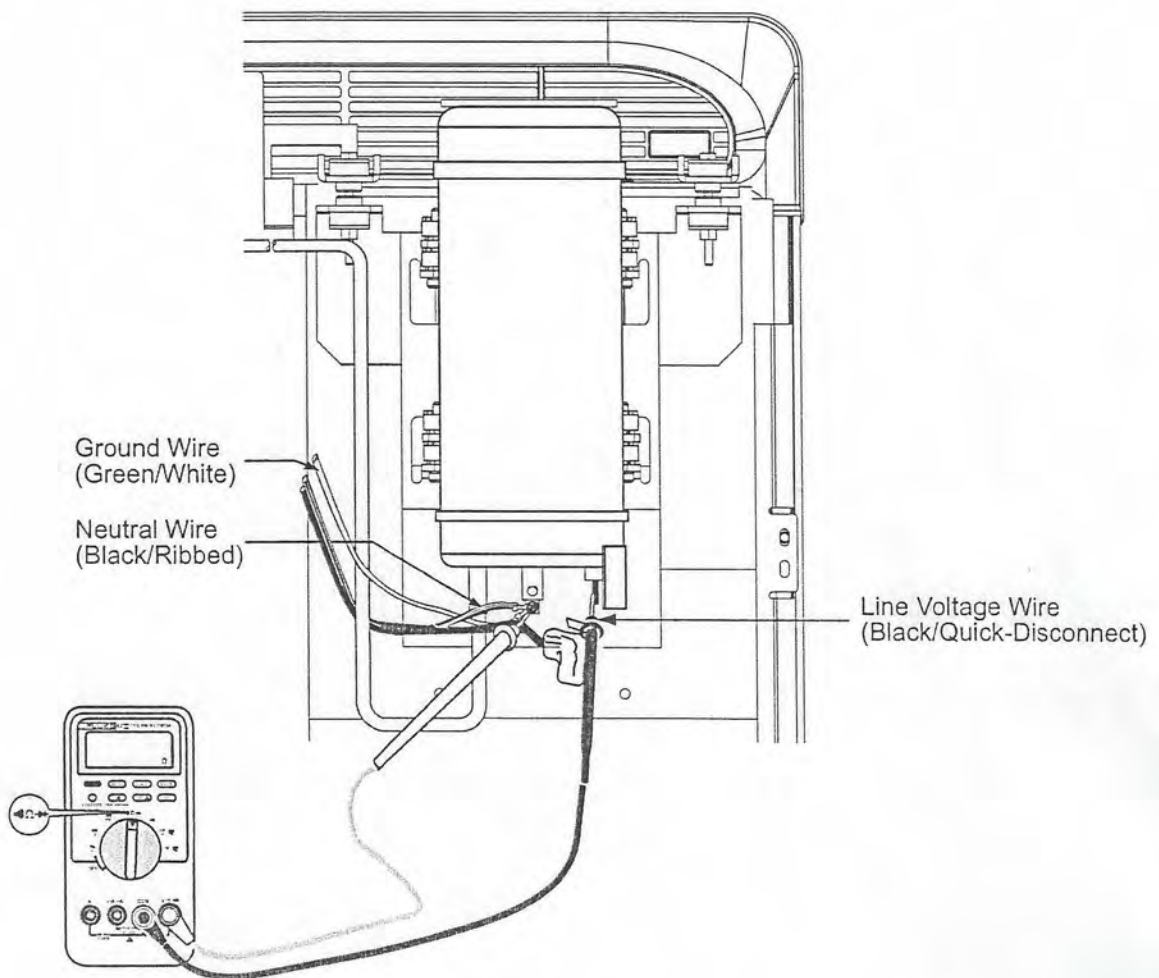

Figure 17. Checking compressor windings resistance.

Procedure E: Measuring Compressor Amp Draw

To measure compressor amp draw:

1. Connect power compressor power leads. See Figure 18.
2. Connect the DC power supply to a charged 12 volt automotive battery. Observe the correct polarity (red +/ black -) when making connections.
3. Turn on refrigerator. The Power Indicator should illuminate.
4. Connect a clamp-on amp meter as shown in Figure 18. Minimum and maximum amp draw appear in Figure 18.

NOTE

Compressor amp draw measurements can also be taken with the refrigerator operating on ac power supply. Make sure input voltages to power supplies are correct.

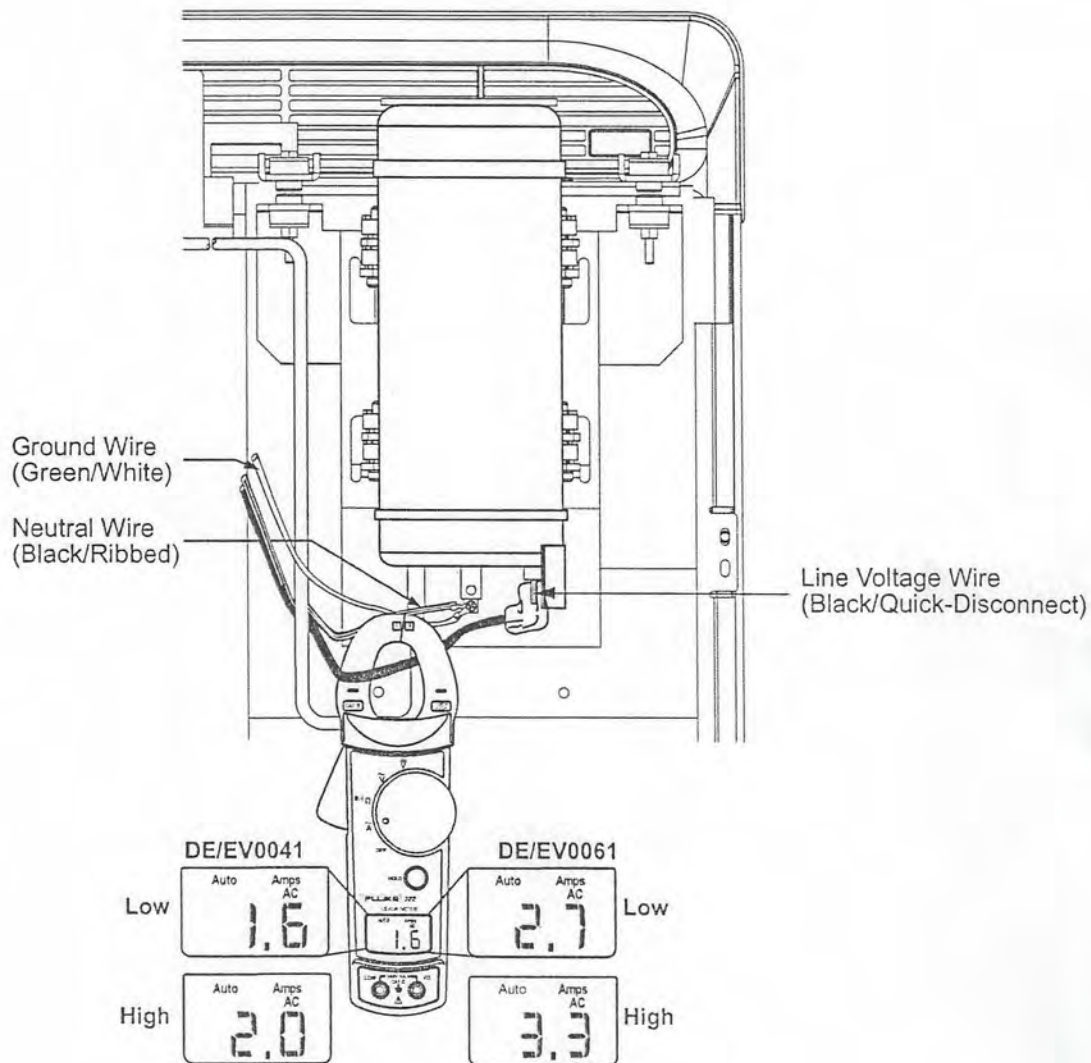

Figure 18. Checking compressor amp draw.

Procedure F: Measuring Thermistor Resistance

NOTE

An open thermistor will prevent the compressor from running.

1. Turn off refrigerator.
2. Disconnect the thermistor assembly wire from DC power board jumper. See Figure 19.
3. Measure thermistor resistance at connector pins as follows.
 - Immerse the thermistor in a bath of ice as shown in Figure 20 to determine if the resistance values change with temperature changes
 - Cross reference thermistor resistance reading using the Resistance Value Table to determine known temperatures.
 - If the thermistor resistance measures within 1.6–29 kOhm, the thermistor is good
 - Replace the thermisto if the reaing is OL.

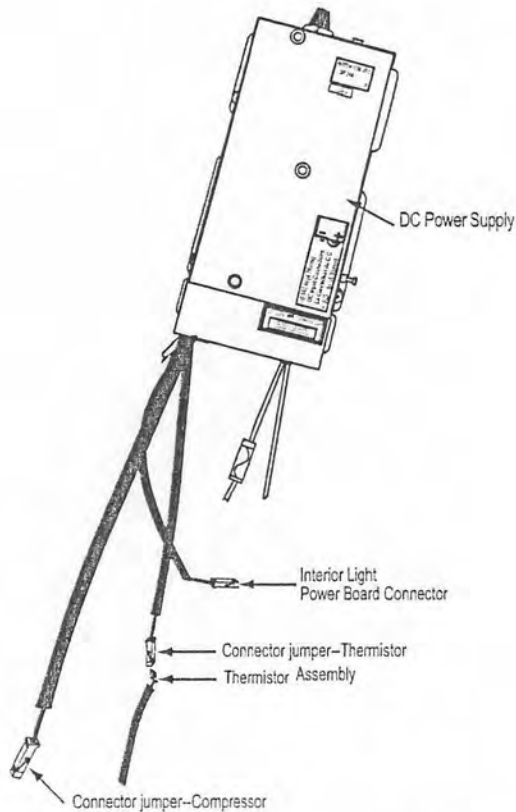

Figure 19. Thermistor connection jumper.

Thermistor Resistance Values Table.

Thermistor Temperature		Allowable Resistance (in kilo Ohm [kΩ])
°F	°C	
		Minimum-Maximum
0	-18	8.7 – 10.7
10	-12	7.0 – 8.6
20	-7	5.7 – 7.0
30	-1	4.8 – 5.7
40	4	4.0 – 4.9
50	10	3.2 – 4.0
60	16	2.5 – 3.1
70	21	1.9 – 2.3
80	27	1.7 – 2.0
90	32	1.6 – 1.9

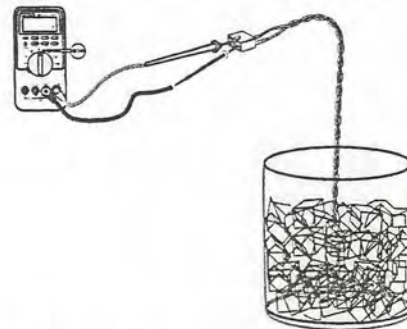

Figure 20. Checking Thermistor resistance with ice bath.

NORCOLD, Inc.
P. O. Box 4248
Sidney, OH 45365-4248

NORCOLD CUSTOMER SERVICE
Telephone: 1-800-444-7210
Fax: 937-497-3183
Web Site: www.norcold.com

