



This program will address the most common system problems associated with the Servel Silhouette supplied by The Dometic Corporation. Our intent is to provide you with a guideline of checks to make, should you encounter one of the following symptoms.

SYMPTOM	CAUSE	REFER TO SECTION	STEP
1. No operation. 	DC Volts Fuse Thermistor Upper PC Board Lower PC Board	3.1 4.12 4.6 4.1 4.2	
2. No operation of upper panel lights.	DC Volts Fuse ON/OFF switch Wiring Upper PC board	3.1 4.12 4.9 4.11 4.1	
3. No operation <input type="checkbox"/> panel lights are on.	Switch Thermistor Wiring Voltage Lower PC board	4.1 <input type="checkbox"/> 2 4.6 4.11 3.1 4.2	1
4. No electrical operation.	Voltage Heating element Thermistor Switch Wiring Lower PC board	3.1 2.1, 4.8 4.6 4.1 <input type="checkbox"/> 2 4.11 4.2	
5. No gas operation <input type="checkbox"/> no spark.	DC volts Igniter (ignition module) Electrode and cable Upper PC board Lower PC board Solenoid valve Wiring Spark gap	3.1 4.3 4.7 4.1 4.2 4.10 4.11 4.7	1
6. No gas operation, sparks <input type="checkbox"/> but no flame.	Gas pressure Orifice Burner Shut-off valve Solenoid valve Lower PC board	5.1 6.2 6.3 6.1 4.10 4.2	
7.No cooling on any mode.	Level Cooling unit	8.2 8.5	
8. No cooling on gas <input type="checkbox"/> cools properly on electric.	LP gas pressure Upper PC board Ignition module Solenoid valve Orifice Burner Flue baffle & flue tube Flue cap	5.1 4.1 4.3 4.10 6.2 6.3 6.4 6.5	

SYMPTOM	CAUSE	REFER TO SECTION	STEP
9. No operation.	AC volt Wiring Fuse Switch AC heater Lower PC board	1 7.1 4.12 4.9 2.1 4.2	
10. Insufficient cooling on all modes.	Level Ventilation Ambient temperature Thermistor Cooling unit	8.2 8.1 8.7 4.6 8.5	
11. Insufficient cooling on electric □ cools properly on gas.	AC volt Element Wiring Switches Thermistor Upper PC board	1 2.1 2.2 4.9 4.6 4.1	
12. Insufficient cooling on gas □ cools properly on electric.	LP gas pressure DC volts Solenoid Flue baffle Flue cap Flue tube Burner Orifice Thermistor Wiring	5.1 3.1 4.10 6.4 6.5 6.4 6.3 6.2 4.6 4.11	
13. Freezes on all modes.	Thermistor Upper PC board Lower PC board	4.6 4.1 4.2	
14. Freezes on electric □ cools properly on gas.	Lower PC board	4.2	
15. Freezes on gas □ cools properly on electric.	Lower PC board Solenoid	4.2 4.10	
16. On gas mode □ sparks while flame is lit.	Spark gap LP gas pressure Orifice Burner	4.7 5.1 6.2 6.3	
17. Won't stay lit on gas.	LP gas Sensor location Sensor wire Low voltage Ignition module Solenoid	5.1 4.5 4.4 3.1 4.3 4.10	
18. LP flame yellow and not very high.	LP gas Orifice Flue and burner	5.1 6.2 6.4	

SYMPTOM	CAUSE	REFER TO SECTION	STEP
19. Burner flame lifting.	Gas pressure Burner alignment Clogged burner Orifice Flue baffle Flue cap	5.1 6.3 6.3 6.2 6.4 6.5	
20. Burner hard to light. 	Gas pressure Electrode Weak spark Ignition wire Burner alignment Orifice DC voltage	5.1 4.5 4.7 4.5 6.3 6.2 3.1	
21. Gas valve chatters.	12 volts Wiring Solenoid	3.1 4.11 4.10	
22. Electrode puts out weak spark.	Electrode adjustment Electrode Electrode wire Ignition module	4.5 4.7 4.7 4.3	
23. Rapid formation of frost.	Air leaks Food storage Cracked liner	8.3 8.6 8.4	
24. Moisture on frame assembly.	Door seal Liner seal to frame High humidity	8.3 8.4 8.8	
25. <u>3-Way Models Only</u> : No DC operation. Cools properly on gas and AC.	DC volts Heating element Switch Wiring Fuses Upper PC board	3.1 4.8 4.9 4.11 4.12 4.1	
26. <u>3-Way Models Only</u> : Insufficient cooling on DC Cools properly on AC and gas.	DC voltage Element Wiring Thermistor Venting	3.1 4.8 4.11 4.6 8.1	

SECTION 1 AC VOLTAGE REQUIREMENTS

This refrigerator is equipped with a three-prong plug for protection against shock hazard and must be connected into a recognized three-prong receptacle.

The electrical cord should be routed in such a manner as to keep it away from the burner cover, flue pipe or other components that could damage the cord's insulation. Proper AC voltage for this style refrigerator is 120 volts.

(132 volts max. □ 100 volts min.)

This voltage selection is made from the control panel on the front of the refrigerator.

The incoming AC voltage is applied to terminals J9 and J10 of the power supply module. (Lower PC board). From there it goes to the necessary areas via the module board to perform the required function.

SECTION 2 AC COMPONENTS

! WARNING

USE EXTREME CAUTION WHEN WORKING ON ANY AC ELECTRICAL COMPONENT OF THE REFRIGERATOR. DISCONNECT AC POWER SOURCE TO REFRIGERATOR BEFORE REPLACING ANY ELECTRICAL COMPONENT. AC VOLTAGES COULD CAUSE SEVERE INJURY OR DEATH.

2.1 AC HEATING ELEMENT

Disconnect the heating element from the terminals J7 and J8 on the power supply module. Using an ohm meter set on the proper scale and read across the two wires, you should get the following readings + or □ 10%:

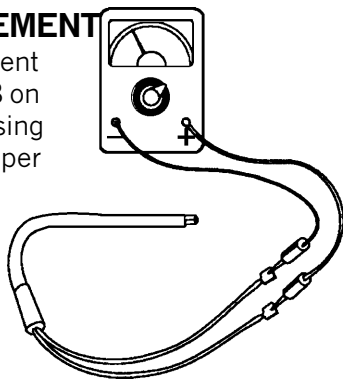

MODELS	WATTS	VOLTS	OHMS
S520	170	110	71.7
S530	170	110	71.7
S620	300	110	40.3
S630	300	110	40.3
S820	300	110	40.3
S830	300	110	40.3
S619	300	110	40.3
S819	300	110	40.3

If the readings do not fall within this range the heating element is defective and should be replaced.

2.2 AC POWER CORD

Disconnect the power cord from the refrigerator and wall receptacle. Using a VOM, check for continuity. Replace the cord is necessary.

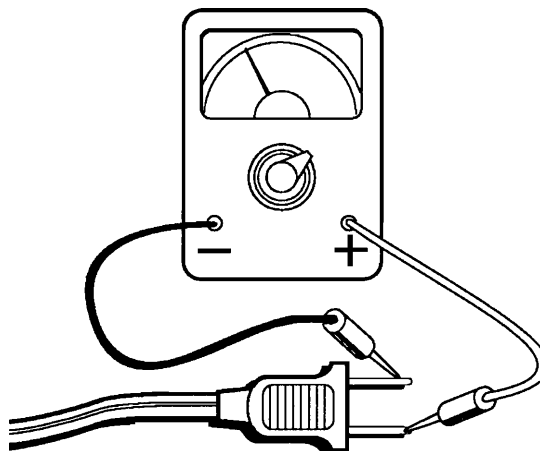

SECTION 3 DC VOLTAGE REQUIREMENTS

! WARNING

USE EXTREME CAUTION WHEN REPLACING DC COMPONENTS. CAUTION MUST BE TAKEN IF DC SUPPLY IS NEAR LP GAS SUPPLY. DC MAY ARC WHEN DISCONNECTING AND IF LP SUPPLY HAD A LEAK, EXPLOSION COULD RESULT CAUSING SEVERE INJURY OR DEATH.

3.1 PROPER DC VOLTAGE

All Servel refrigerators require a DC volt supply even though some models are designed to operate on 120 volts AC and LP gas only. (A DC volt control circuit is required to maintain the automatic ignition.) This supply voltage should come directly from a battery.

The DC lead connections are at the back of the refrigerator. Correct polarity must be observed when connecting to the battery supply. For proper operation, the DC voltage range is 11 minimum to 15.4 maximum.

! CAUTION

IMPROPER CONNECTION WILL CAUSE IRREPARABLE DAMAGE TO THE CIRCUIT BOARD.

The distance the current must travel from the battery to the refrigerator dictates the AWG wire size to be used. SEE CHART ON FOLLOWING PAGE.

	S 520		S 530	
	min. wire size	max. fuse size	min. wire size	max. fuse size
0 - 20'	18 AWG	6 Amp	12 AWG	25 Amp
over 20'	18 AWG	6 Amp	10 AWG	30 Amp

	S 620		S 630	
	min. wire size	max. fuse size	min. wire size	max. fuse size
0 - 20'	18 AWG	6 Amp	10 AWG	30 Amp
over 20'	18 AWG	6 Amp	8 AWG	40 Amp

	S 820		S 830	
	min. wire size	max. fuse size	min. wire size	max. fuse size
0 - 20'	18 AWG	6 Amp	10 AWG	30 Amp
over 20'	18 AWG	6 Amp	8 AWG	40 Amp

SECTION 4 DC COMPONENTS

4.1 UPPER PC BOARD

If you have voltage into the power supply board (see Section 4.2) and voltage out on P1 terminal 5, you should then check the wire harness for continuity. If this check shows all wires having continuity, the fault lies in the upper PC board and it should be replaced.

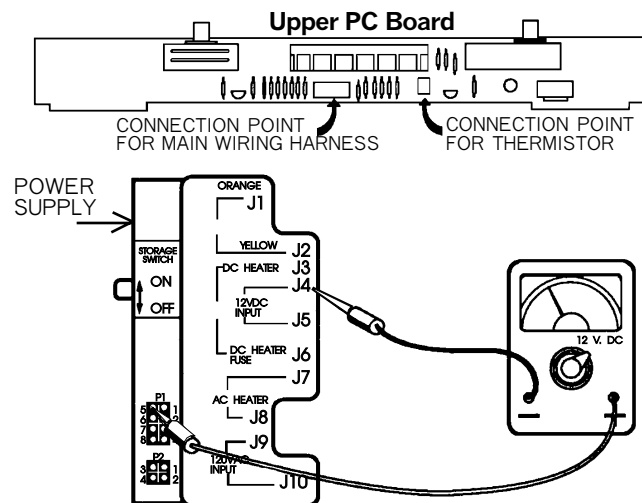

NOTE: This test is required to verify if voltage is going to the upper PC board.

When testing the refrigerator's operation, make sure the thermostat is set to its coldest position. When working with a unit that has an interior light, make sure the storage switch on the rear of the refrigerator is turned on.

4.2 LOWER PC BOARD

The following procedure will help you determine if the refrigerator is receiving proper DC volts. To perform the following test, you will need a VOM set to read DC volts. Gain access to the power board (lower PC board) and proceed to test in the following manner.

1. INCOMING DC VOLTS:

On the power board (lower PC board) probe with a voltmeter between terminals J5 (+) and J4 (□). This is to ensure the vehicle's DC volt is connected to the refrigerator.

If there is a positive reading 11 to 15.4, continue on to the next test procedure. If the reading is outside this range, see Section 3.1.

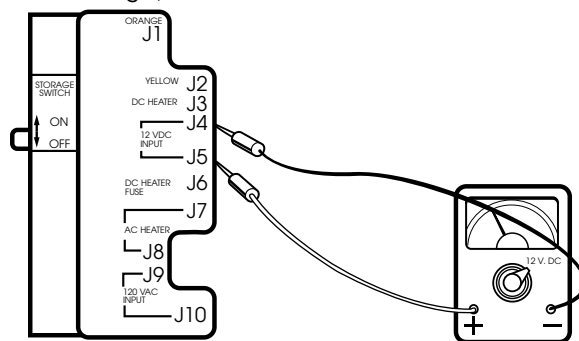

2. STORAGE SWITCH OPERATION

The next test procedure is to make sure the storage switch is in the "ON" position.

NOTE: Only interior lighted models have this storage switch.

Using a volt meter, probe between terminals J1 (+) and J2 (□). A reading equivalent to the vehicle's DC volt supply should be present. If not, either the switch is defective or the 3-amp DC fuse F1 on board is defective. Check continuity of fuse. If good, replace module board. If the fuse is bad, replace it. Remember to find the cause of fuse failure.

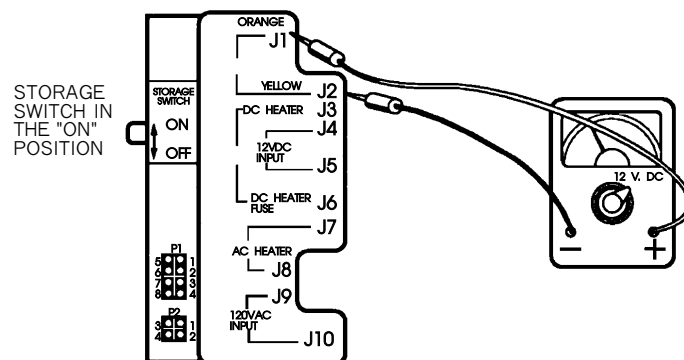

3. DC VOLTS P1 (8 PIN)

The next check is to disconnect the low voltage harness from the P1 connector at the lower left corner of the power supply module (lower PC board storage switch on). Probe between P1 terminal 5 and terminal J4 (□). A voltage reading equivalent to the supply voltage should be present. If not, the power module should be replaced.

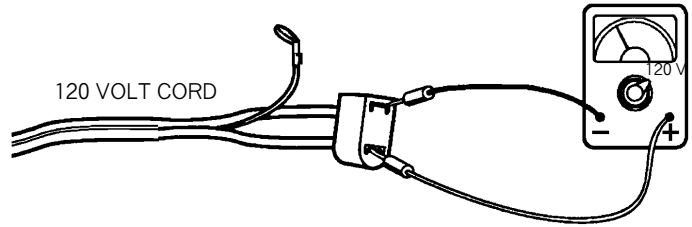
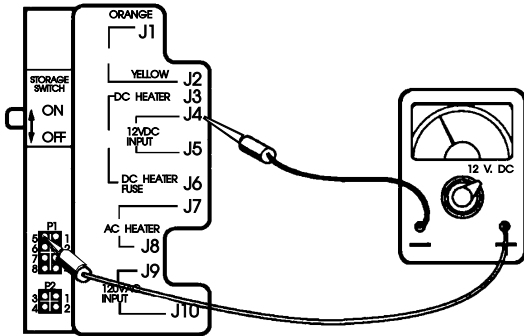

If line voltage is present, either the 5-amp AC fuse is open, or the relay has not been activated. If the fuse is open, remove the board from the refrigerator and remove module board from cover. Replace 5-amp fuse and remount board and wire back into system.

5. AC RELAY

To check the AC relay, test between terminal 8 of the connector (P1) and terminal J4.

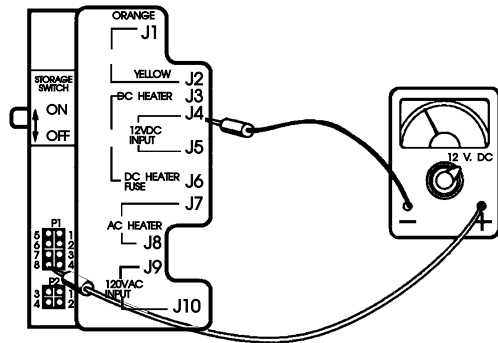

NOTE: This is a DC voltage check.

If a voltage of less than 1 volt DC is present, then check the 5-amp AC fuse. If defective, replace.

If the fuse is not open and 1 volt or less exists on P1-8, then the AC heater relay is defective and the lower PC board should be replaced.

If DC volts are present on the P1-8 terminal, then check continuity of the low voltage harness. Also check the temperature sensor. See Section 4.6.

Another check of the AC relay is to remove the power harness from P1 and temporarily ground P1-8. You should get an audible click and 120 volts should be present between terminals J7 and J8.

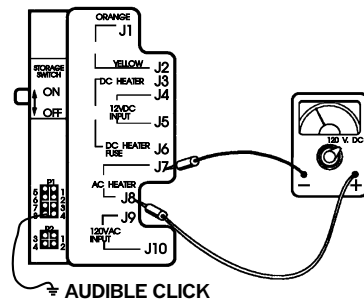

If these prove OK, the fault is likely in the eyebrow board and it should be replaced. The system should then be retested.

4. LOWER PC BOARD AC CHECK

! WARNING

USE EXTREME CAUTION WHEN WORKING THE AC ELECTRICAL COMPONENTS OF THE REFRIGERATOR. BEFORE REPLACING ANY ELECTRICAL COMPONENTS, MAKE SURE THE AC POWER SUPPLY HAS BEEN DISCONNECTED FROM THE REFRIGERATOR. ELECTRICAL VOLTAGES CAN CAUSE SEVERE INJURY OR DEATH.

The following procedure will help determine if the AC operation is functioning. Set the switches on the eyebrow board to the proper position (electric and AC). The AC indicator should illuminate. If not, refer to the INCOMING DC VOLTS. Place the temperature selector into the coldest position with the refrigerator compartment door open. The AC heater relay on the lower PC board should be activated if the refrigerator cavity is warm enough. AC volts should be present at J7 and J8.

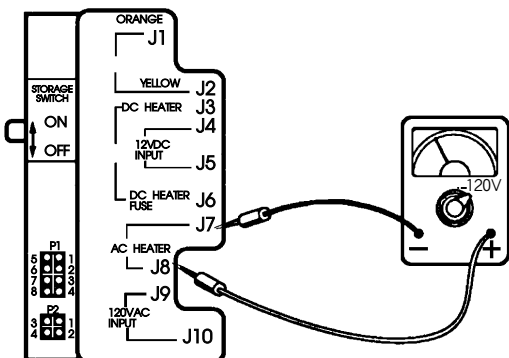

If not, check to ensure that 120 volts exist on the incoming cord. Unplug from board and check.

4.3 IGNITION MODULE (IGNITER)

Before diagnosing the ignition module, be sure the ON-OFF switch is on and the temperature sensor (see Sec. 4.6) and upper PC board (see Sec. 4.1) are good.

The ignition module has multiple functions. During gas operation it performs the following:

- Supplies voltage to ignition electrode.
- Applies DC volts to open gas valve.
- Senses flame through sensor electrode.
- If burner continues to burn, it turns off spark.
- If unit fails to light within a given time (10 seconds), it closes gas valve and lights check light (red wire).

IGNITION MODULE CHECK

- Remove ignition module, check back of connection strip. If corroded, clean with a pencil eraser, reconnect to wire harness.
- Check for DC volts (11 to 15.4) at connector between power supply and control module. Power will be present for 10 seconds between blue wire (+) P2-3 and green wire (□) P2-4. Also check the wire harness at the ignition module. If you have proper DC volts at this connection, replace defective ignition module. If you do not have proper DC volts, replace power supply (lower PC board).

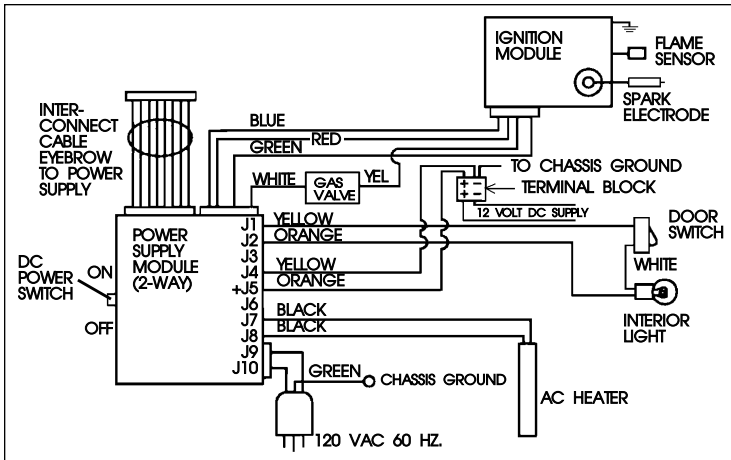

4.4 FLAME SENSOR WIRE

The sensor electrode sends a signal back to the ignition module to inform it that a flame has been established.

To check the sensor and wire, follow these steps.

- Set ohm meter on highest scale.
- Disconnect wire to electrode.
- Check for continuity between the wire and ground. Any reading indicates a defective electrode, replace it.

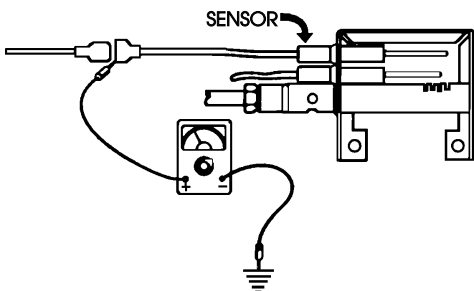

4.5 FLAME SENSOR

- Check for proper alignment to burner. Sensor should be in flame path.
- Check for cracked ceramic.
- Check for loose wire connection.
- Check for carbon build-up.

Correct any burner errors, replace any defective parts.

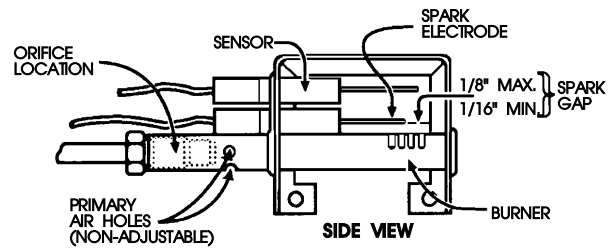
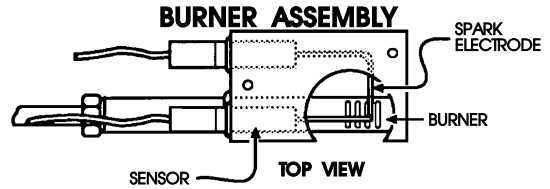

4.6 THERMISTOR

To determine if the temperature sensor is functioning properly, perform the following test.

Remove the upper eyebrow (PC board). Disconnect the thermistor harness from the board. Using an ohm meter set on the proper scale, place one probe on each terminal point. If the thermistor is at room temperature (70 to 75°F) you should get a reading of approximately 3000 ohms. Next, place the thermistor in a glass of ice water. Wait 2 to 3 minutes. Using an ohm meter, place a probe on each terminal point. You should get a reading of approximately 9000 ohms. Normal failure for this type of device is to have a very high resistance. A reading of 75,000 ohms or higher indicates the thermistor is defective and should be replaced. A defective thermistor could cause an over-cooling on all modes.

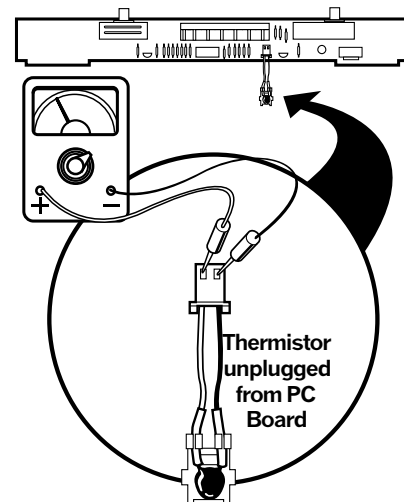

4.7 SPARK ELECTRODE (SPARK GAP AND CABLE)

The function of this component is to supply a spark to the burner to ignite the LP gas. Proper alignment of the electrode to the burner 1/16" to 1/8" above the burner.

To check for a continuity reading, do the following test.

1. Turn selector switch off.
2. Disconnect the wire that goes to the electrode, from the ignition module.
3. With the volt ohm meter set on the proper scale, check between the electrode wire and ground. Any reading indicates a bad electrode. Replace the electrode.

NOTE: A weak spark or an ignition cycle of less than 10 seconds indicates a voltage supply problem to the refrigerator. This should be corrected.

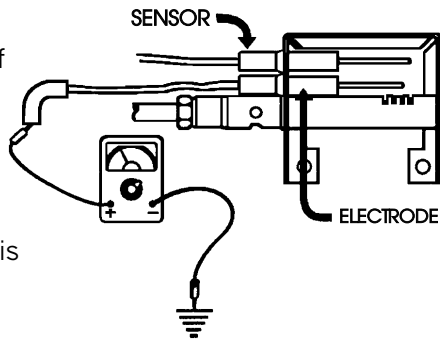

4.8 DC-VOLT HEATING ELEMENT

Disconnect the heating element from J3 and J6 on the power supply module. Using an ohm meter set on the RX1 scale, read across the two wires of the heating element. You should get the following reading: (Plus or minus 10%).

MODEL	WATTS	VOLTS	OHMS
S620	225	14	.87
S830	225	14	.87
S530	150	14	1.30

If the element does not fall within the above range, it is defective and should be replaced with a proper size Servel heating element. **NOTE:** If a precise ohm meter is not available, a continuity reading will indicate an open or complete circuit. If the test results show an open circuit, replace the element.

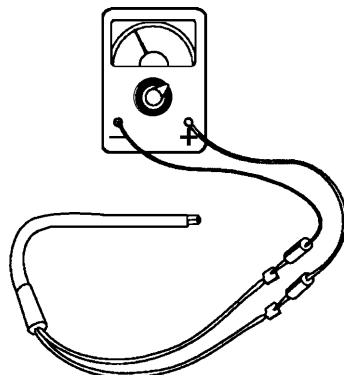

4.9 ON-OFF SWITCH

Incorporated in the upper PC board is an ELEC □ OFF □ GAS switch. Be sure it is NOT in the OFF position. Also on models that have an interior light, an ON-OFF switch is on the lower PC board. Be sure it is in the ON position.

To check the switch on the lower PC board, see Section 4.2. To check the switch on the upper PC board, see Section 4.1.

3 - Way Models

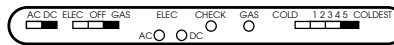

2 - Way Models

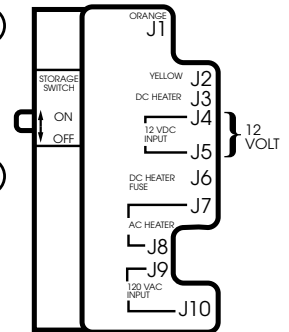
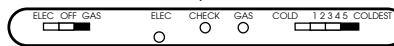

4.10 LP GAS COMPONENTS

SOLENOID VALVE

The solenoid valve is a DC volt activated valve. To check this component you will need to perform the following tests.

1. Hook up manometer at test port.
2. Check for DC volts at gas valve terminals while unit is in trial for ignition. If 11 volts or more is present and pressure is low, replace valve.
3. If DC voltage is not present at the valve, replace ignition module.

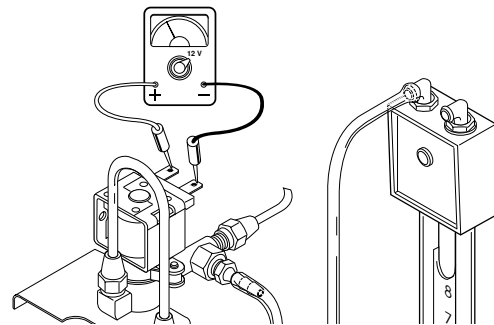

4. Valve chatters Low input voltage to valve.
 Defective temperature sensor.

4.11 WIRING

WIRE HARNESS

This unit has two wire harnesses. The four wire harness goes from P2 on lower PC board to the ignition module (gas valve circuit). The seven wire harness goes from the lower PC board (P1) to the upper PC board. Their purpose is to complete the necessary electrical connections between module boards.

These wire harnesses are color coded for easy diagnostic procedures. If the pin connectors are in question and you have to tighten them, care should be taken as these connectors are quite small and could be damaged. If damage does occur, the complete harness should be replaced.

To check the harness, you should do a continuity reading on the harness.

LOWER PC BOARD WIRE HARNESS

The low voltage harness should be checked for continuity. This should be done between the upper eyebrow connector and the lower PC board connector. Lack of continuity between pins attached to the same wire indicates a defective wire. Either repair the defect or replace the harness.

P-2 Eye Brow Board

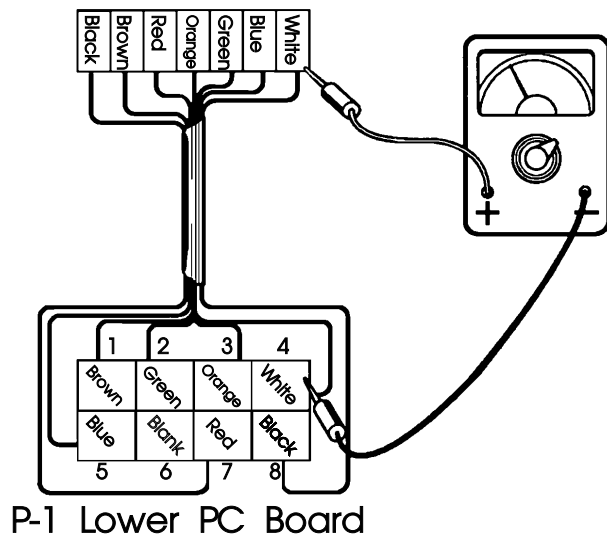

If the above procedure is positive and there is no operation of the upper PC board with the corresponding switch in the proper position, then the eyebrow board is defective and should be replaced.

4.12 FUSE (3A)(5A)(20A ON 3-WAY MODELS)

Fuses are designed as a protection device for equipment and user. **(Never over-fuse a circuit).**

A defective fuse indicates high current draw or direct short to ground.

To check fuse, remove it from the power supply module (lower PC board) and the 20 amp fuse from the refrig-

erator base (3-way models only). Using a volt ohm meter, remove the fuse from its holder and make a continuity check on the fuse. If it is defective it will have to be replaced. You will also have to find the cause for fuse failure. Repair the failure, replace the fuse and retest the system.

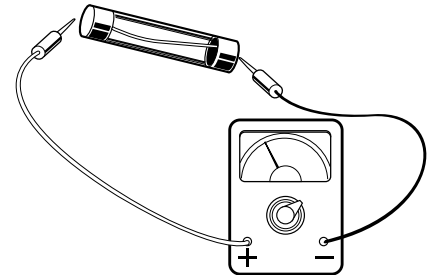

**SECTION 5
LP GAS REQUIREMENTS**

The Servel refrigerator uses liquid petroleum (LP) that is supplied through a pressure regulator at 11" WC to the main burner. Any pressure less than 11" WC can affect the operation of the refrigerator when on gas mode.

5.1 HOW TO CHECK LP PRESSURE

Hook up a manometer to the pressure test port at the back of the refrigerator. Set the refrigerator to the gas mode and start the unit. During ignition cycle you should get a gas pressure reading of 11" to 12" WC.

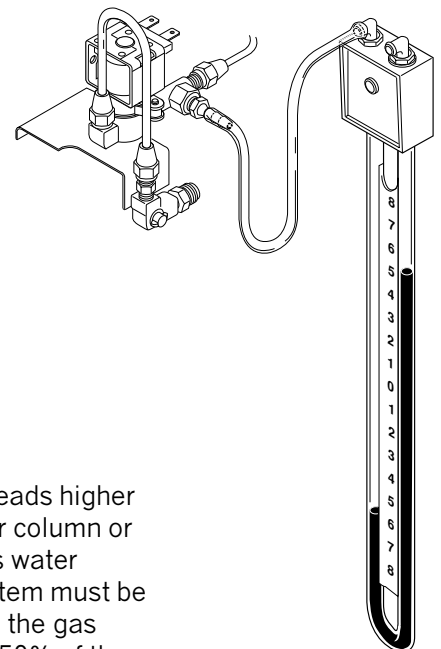

If your manometer reads higher than 12 inches water column or lower than 11 inches water column, the gas system must be checked. Make sure the gas system has at least 50% of the RV's BTU's on at the time the system is being adjusted.

SECTION 6 LP GAS COMPONENTS

6.1 SHUT-OFF VALVE

The purpose of the shut-off valve is to stop the flow of LP to the burner. To check its operation hook up a manometer to the test port. Apply pressure to manometer, turn shut-off valve off. If pressure drops to zero, the shut-off valve is good. If pressure stays up any amount, the shut-off is defective and must be replaced.

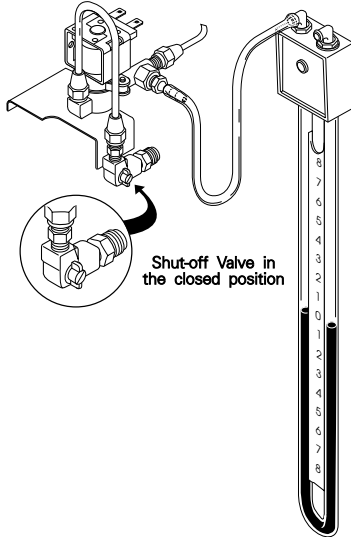

6.2 ORIFICE

1. Remove the orifice and clean with an alcohol base solvent and let air dry. **DO NOT CLEAN THE ORIFICE BY USING A STRAIGHT PIN OR OTHER SHARP OBJECT.**

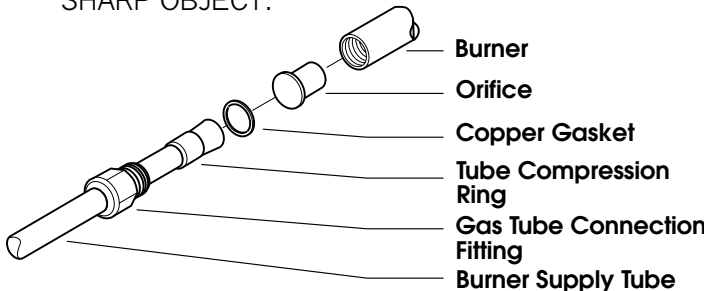

Be sure the copper gasket and tube compression ring are in place when reassembly takes place.

6.3 LP BURNER

1. Make sure burner is clean, no spider webs, carbon build-up or rust.
2. Make sure when reassembly is being done that the burner is secured properly in the housing.

After burner has been cleaned of any type of blockage, make sure it is properly aligned when put back in housing. Make sure the electrode and igniter are positioned properly. (See Sec. 4.5).

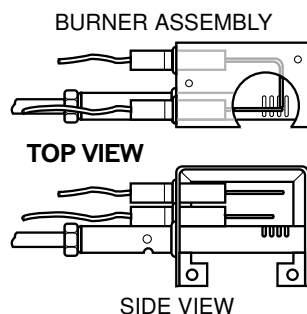

6.4 FLUE BAFFLE & FLUE TUBE

The purpose of the baffle is to slow the rise of heat when on LP operation. Gain access to the baffle wire either by removing the roof vent or take the refrigerator out of the coach.

1. Remove the baffle from the flue tube. Using a flue brush, clean the flue. The flue brush part number is 0151404.001.
2. Inspect the baffle. If the end has burnt away it will be necessary to replace the baffle. It is very important that you order the correct baffle for the refrigerator you are working on. Reinstall the baffle and test unit for proper operation.

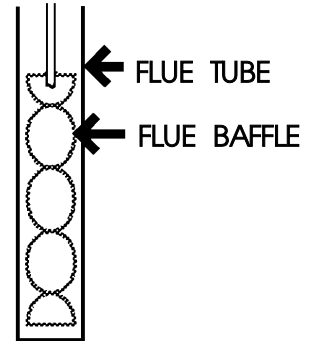

The following illustration will give you proper baffle length.

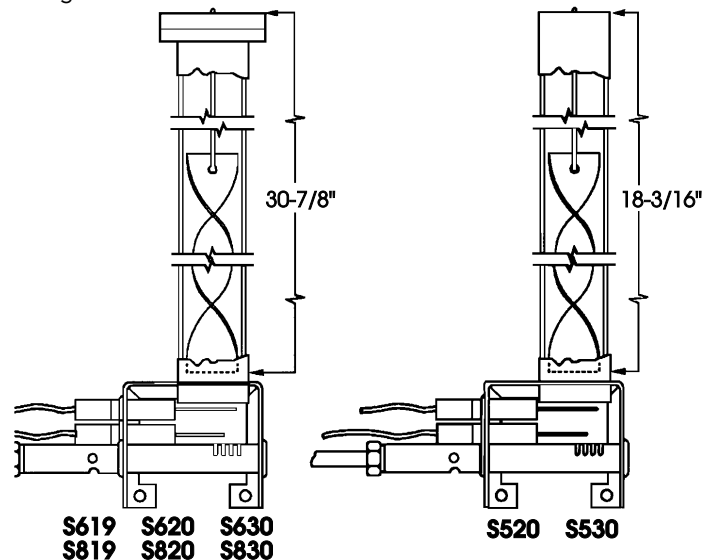

The bottom of the flue baffle is 1-3/8" above burner on all models.

6.5 FLUE CAP

The flue cap is used to help prevent down drafts and hold the wire that the spiral baffle is attached to. It is important that the cap be positioned properly when unit is operating on gas.

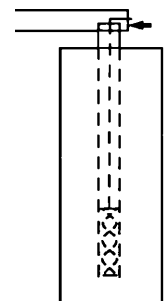

SECTION 7 WIRING

7.1 WIRING DIAGRAMS

The wiring diagrams and connection diagrams should be followed when performing electrical checks, either 12-volt DC or 120 volt AC. The information supplied along with the color codes of the wires should allow for easy electrical repairs if necessary. If wire replacement is necessary, be sure you use the same size wire so it will carry the voltage load of that circuit. Use the wiring pictorial and diagram that is on the refrigerator you are working on.

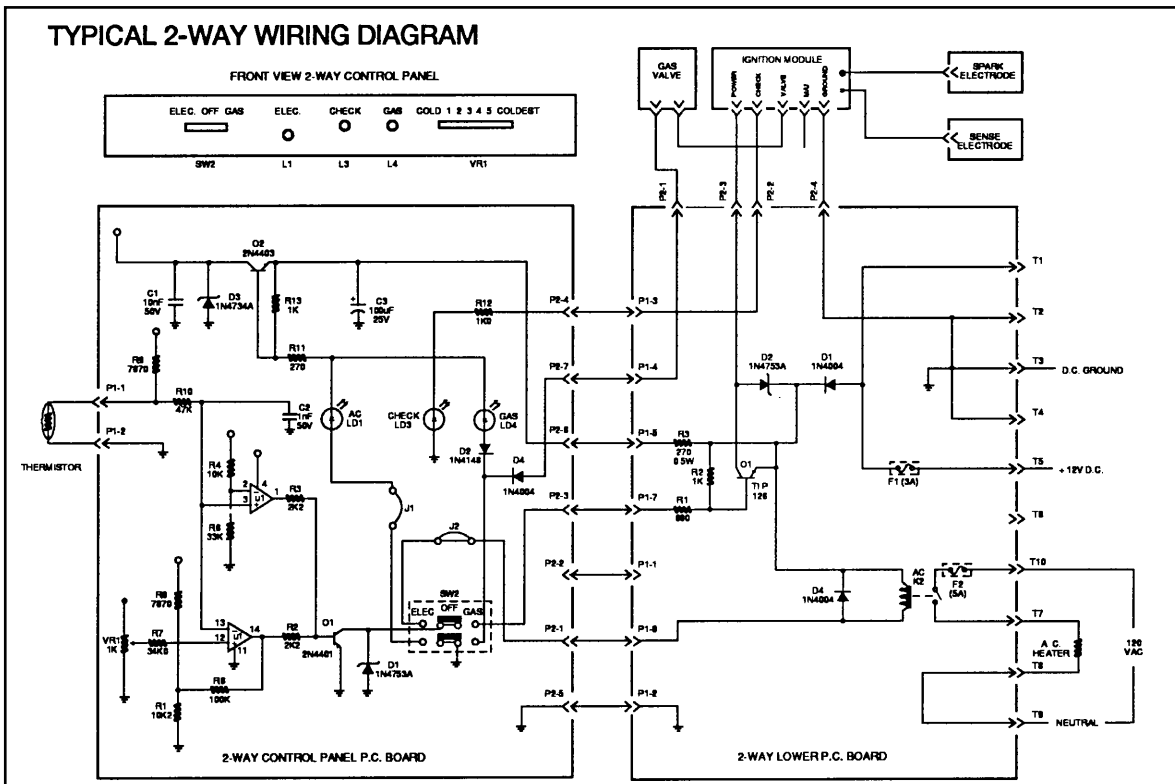
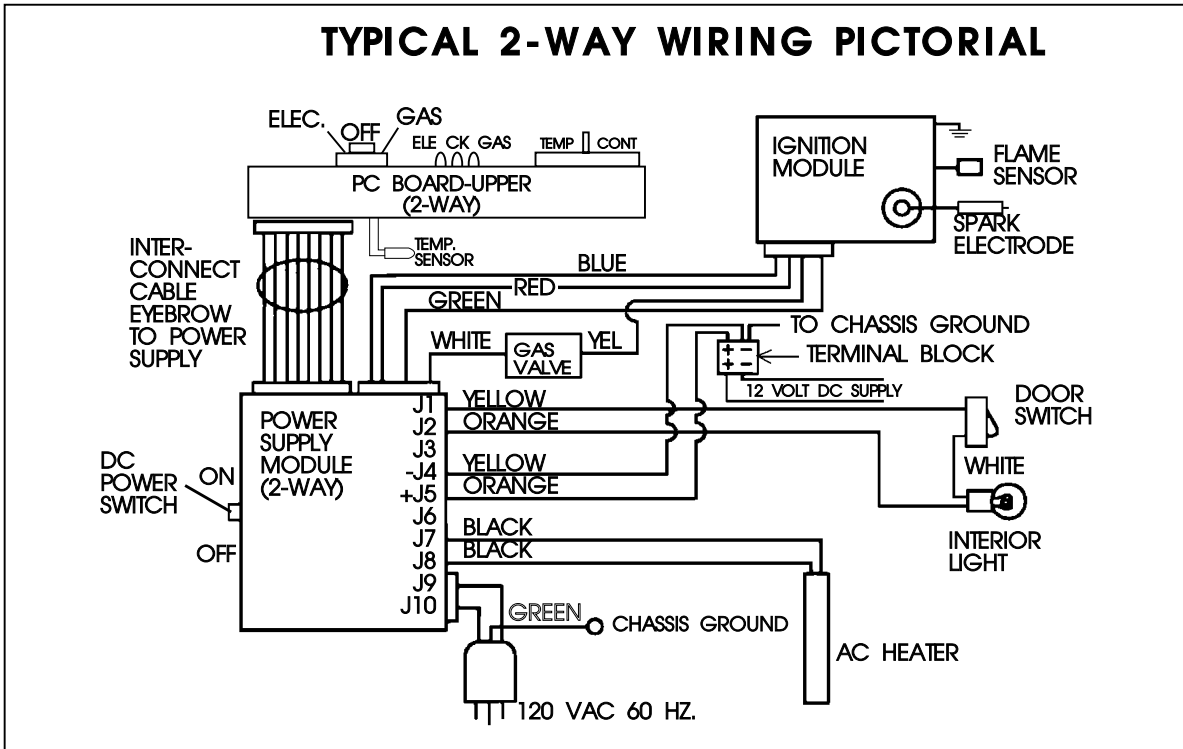

SECTION 8 GENERAL INFORMATION

8.1 VENTING

Installation must assure complete isolation of the living space of the recreational vehicle and the combustion system of the refrigerator. Proper installation requires that one lower combustion air intake and one upper exhaust vent be installed. Follow the proper installation information that comes with each refrigerator. The lower vent must be flush or below bottom of refrigerator.

The cooling unit must receive a continual supply of air in order to maintain proper refrigerator cooling. The air passage from the lower vent door to the refrigerator coils and from the coils up through the roof vent must be unobstructed. If air becomes trapped by obstructions, the refrigerator will start to lose its ability to cool. Proper venting will create a chimney effect to insure adequate circulation.

It is important to block off the area above the refrigerator cabinet from the venting zone. Also, air space at the sides of the refrigerator should be minimized to prevent pockets of hot air from forming.

Without adequate ventilation and/or with partial blockage of flue exhaust, incomplete combustion (on gas operation) can cause carbon monoxide to form. Not only does the refrigerator lose efficiency but a poisonous gas can result. The roof jack opening must be centered directly above the flue and condenser. The vent must also be of proper size.

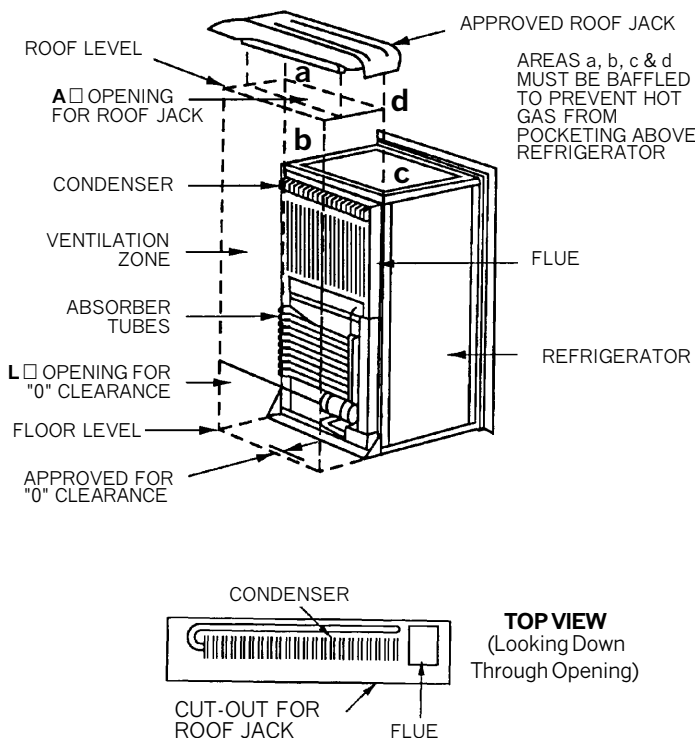

POCKETS SHOULD BE BAFFLED FOR PERFORMANCE EFFICIENCY, ALTHOUGH NOT REQUIRED FOR CERTIFICATION.

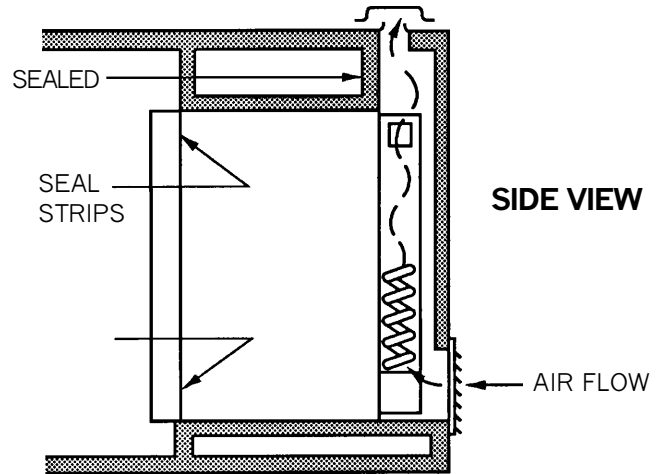

CERTIFIED VENT KITS

Number	Type	Cut-Out
3100528	Plastic Roof Vent Base	5" x 24"
3100529	Plastic Roof Vent Cap	
2214	Lower Side Vent	14" x 22"
Kit 1	Includes Above Parts	

8.2 LEVEL

The Servel refrigerators do not require critical leveling such as required by other absorption type refrigerators. Normal vehicle leveling to provide comfort for the occupants is satisfactory for refrigerator operation. This will be well within the operation limits of 3 degrees off level side-to-side, and 6 degrees off level front-to-back of the RV.

8.3 DOOR SEAL (AIR LEAKS)

These gaskets are magnetic and when the door is closed create a seal. The purpose is to keep warm room air out of the refrigerator. To test a door gasket seal, place a dollar bill between the door gasket and the metal frame. Close the door, remove the dollar bill. You should encounter some resistance. Perform the same test on all four sides of the refrigerator door. Any area that shows little or no resistance indicates a defect in the gasket. Warm the refrigerator and using a hair dryer, carefully warm the gasket in the area that did not make a good seal. Close the door and let the seal return to normal room temperature. If this does not correct the poor seal, it will require replacement of the complete door.

8.4 CRACKED LINER

A mold mark should not be mistaken as a crack in the liner. Make sure the crack is such that you can see a split in the plastic. If in fact the liner is cracked, it would be necessary to contact the company and follow their instruction on how to handle.

LINER SEAL TO FRAME

There is a seal that is applied to the liner in the area where the metal frame makes contact with the plastic liner. If this seal is incomplete, cold air can migrate out to the metal frame and cause condensation to form.

8.5 COOLING UNIT

This is the heart of the refrigerator. It creates the cold necessary to maintain stored food at a safe temperature. It is a self-contained unit and cannot be repaired if it fails. The only recourse is to replace it. If the operation of the cooling unit is in question, we suggest you check to make sure you have a proper installation, zero clearance on the sides, top and 1/2" from combustible surface at back of refrigerator. The unit should also be level. Take a good heating element of proper wattage and install it in the cooling unit heater pocket. Wire it direct to 120 volt AC. Let the refrigerator run for approximately 12 hours. The interior should be cold by that time. If not, you have a defective cooling unit and it must be replaced. If you smell ammonia in or around the refrigerator, the cooling unit is defective and must be replaced.

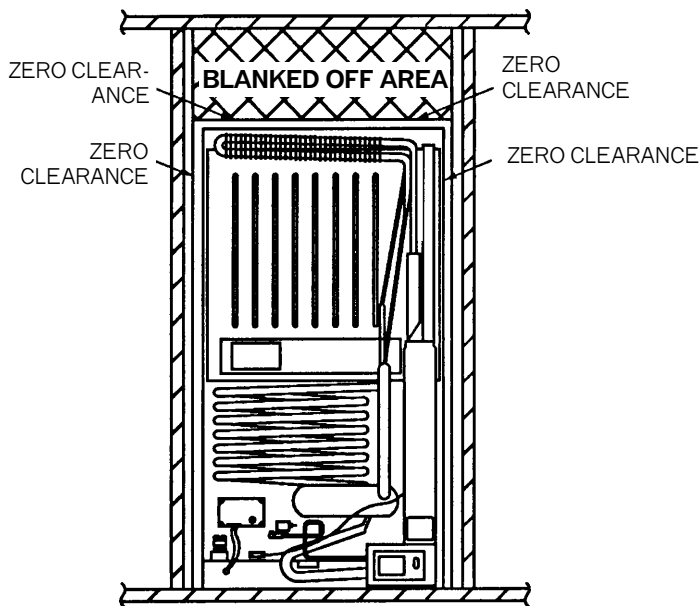

8.6 FOOD STORAGE

Proper refrigeration requires free air circulation within the food storage compartment. Restricted air circulation within this compartment will cause higher cabinet temperatures. To correct this simply rearrange your food

items. Never cover the shelves with paper or large storage containers; they restrict air circulation. Odors or highly flavored foods should always be stored in covered dishes, plastic bags or wrapped in foil. NEVER PUT HOT FOOD INTO THE REFRIGERATOR.

To reduce frost formation in and on the freezing compartment, cover stored liquids and moist foods. Do not leave door open any longer than necessary.

The coldest position in the refrigerator is underneath the cooling evaporator fins and at the bottom of the refrigerator. The least cold area is on the upper door shelves. This should be considered when different types of food are placed in the refrigerator.

8.7 AMBIENT TEMPERATURE

This is the temperature surrounding the RV as well as the back of the refrigerator. As the ambient temperature goes up □ it will also raise the temperature in the area of the cooling unit. Improper venting at this point will cause the cooling unit to have reduced efficiency, therefore not allowing the refrigerator to get cold enough.

8.8 HIGH HUMIDITY

High humidity can have an effect on the amount of condensation that builds up on the main frame of the refrigerator. In some cases it can develop to such a degree that it will run off the frame. As the humidity is reduced, the sweating will decrease.

CONTENTS	PAGE NO.
SERVEL SILHOUETTE DIAGNOSTIC FLOW CHART ...	1
<hr/>	
SECTION 1	
AC VOLTAGE REQUIREMENTS	4
<hr/>	
SECTION 2	
AC COMPONENTS	
2.1 AC Heating Element	4
2.2 AC Power Cord	4
<hr/>	
SECTION 3	
DC VOLTAGE REQUIREMENTS	
3.1 Proper DC Voltage	4
<hr/>	
SECTION 4	
DC COMPONENTS	
4.1 Upper PC Board	5
4.2 Lower PC Board	5
4.3 Ignition Module (Igniter)	7
4.4 Flame Sensor Wire	7
4.5 Flame Sensor	7
4.6 Thermistor	7
4.7 Spark Electrode (Spark Gap) and Cable	8
4.8 DC-Volt Heating Element	8
4.9 On-Off Switch	8
4.10 LP Gas Components	8
4.11 Wiring	8
4.12 Fuse (3A) (4A) (20A on 3-Way Models)	9
<hr/>	
SECTION 5	
LP GAS REQUIREMENTS	
5.1 How to Check Pressure	9
<hr/>	
SECTION 6	
LP GAS COMPONENTS	
6.1 Shut-Off Valve	10
6.2 Orifice	10
6.3 LP Burner — Clogged & Alignment	10
6.4 Flue Baffle & Flue Tube	10
6.5 Flue Cap	10
<hr/>	
SECTION 7	
WIRING	
7.1 Wiring Diagrams	11
<hr/>	
SECTION 8	
OTHER	
8.1 Venting	13
8.2 Level	13
8.3 Door Seal (Air Leaks)	13
8.4 Cracked Liner	14
8.5 Cooling Unit	14
8.6 Food Storage	14
8.7 Ambient Temperature	14
8.8 High Humidity	14



Manual provided courtesy
Bryant RV Services
www.byantrv.com

All manuals are believed to be released for distribution, and/or in the public domain.

Service manuals provided with the understanding that persons using them are well versed in proper safety practices, and are familiar with basic safety procedures, including, but not limited to safety procedures dealing with 120 volt electricity, high amperage 12 volt circuits an LPG (propane) systems.

If in doubt, consult a professional (better safe than sorry).